



i-PILOT®

Owner's Manual

INTRODUCTION

THANK YOU

Thank you for purchasing the Minn Kota® i-Pilot®. This revolutionary control system uses GPS technology to record and store tracks and locations which are then used to deliver unprecedented levels of boat control. Intuitive features and wireless control help to accurately position your boat and improve your bait presentation. i-Pilot navigates and positions your boat for you, so you can focus on fishing.

REGISTRATION

Remember to keep your receipt and immediately register your trolling motor. A registration card is included with your motor or you can complete registration on our website at minnkotamotors.com.

SERIAL NUMBER

Your Minn Kota 11-character serial number is very important. It helps to determine the specific model and year of manufacture. When contacting Consumer Service or registering your product, you will need to know your product's serial number. We recommend that you write the serial number down so that you have it available for future reference.

NOTICE: The location of the serial number, for the i-Pilot navigation system, is different based on the motor it is installed on. The motor serial number encompasses the i-Pilot navigation system. Refer to the images to the right to determine location based on motor model.

PRODUCT INFORMATION (For Consumer Reference Only)

Model: _____

Serial Number: _____

Purchase Date: _____

Store Where Purchased: _____

NOTICE: Do not return your Minn Kota product to your retailer. Your retailer is not authorized to repair or replace this unit. You may obtain service by: calling Minn Kota at (800) 227-6433; returning your product to the Minn Kota Factory Service Center; sending or taking your product to any Minn Kota authorized service center. A list of authorized service centers is available on our website, at minnkotamotors.com. Please include proof of purchase, serial number and purchase date for warranty service with any of the above options.

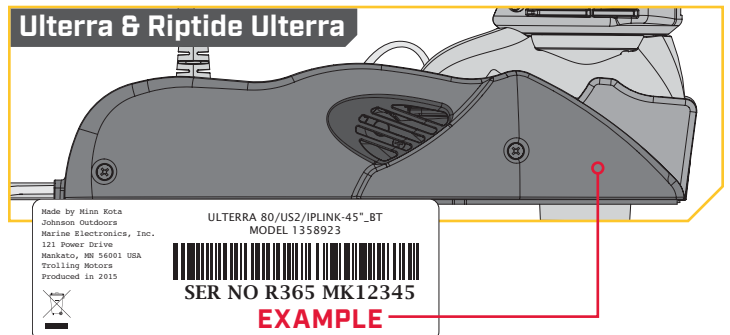
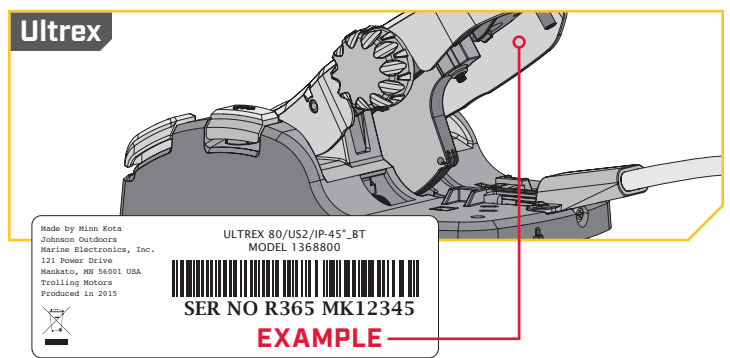
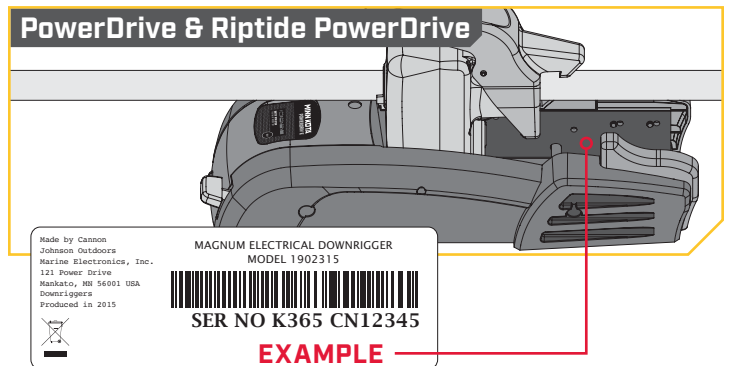
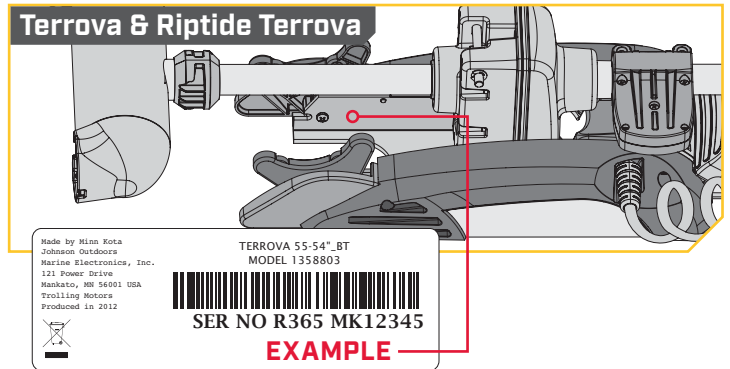

TABLE OF CONTENTS

| | |
|---|----|
| SAFETY CONSIDERATIONS | 4 |
| WARRANTY | 5 |
| FEATURES | 6 |
| REMOTE BUTTONS | 7 |
| HEADER & ICONOGRAPHY | 8 |
| DISPLAY SCREEN | 9 |
| GETTING STARTED | 10 |
| The i-Pilot System | 10 |
| System Startup..... | 11 |
| AUDIO MODES | 13 |
| Audio Mode Control | 13 |
| SPOT-LOCK | 15 |
| How Spot-Lock Works | 15 |
| Spot-Lock Functions..... | 15 |
| CRUISE CONTROL | 18 |
| i-Pilot with Cruise Control..... | 18 |
| Working with Cruise Control..... | 19 |
| HIGH SPEED BYPASS | 21 |
| Motor Speed and High Speed Bypass | 21 |
| Controlling High Speed Bypass | 21 |
| AUTOPILOT | 23 |
| i-Pilot with Autopilot..... | 23 |
| AutoPilot Modes | 23 |
| Working with AutoPilot..... | 24 |
| iTRACKS | 26 |
| Understanding iTracks..... | 26 |
| Working with iTracks | 27 |
| iTrack Arrival Modes..... | 29 |
| HEADING SENSOR | 30 |
| Heading Sensor Features..... | 30 |
| Heading Sensor Functions..... | 30 |
| Light Patterns | 30 |
| Installation..... | 31 |
| Working with the Heading Sensor..... | 37 |
| MOTOR CONTROLS | 41 |
| TALON CONTROLS | 46 |
| REMOTE CONTROLS | 53 |
| i-PILOT APP | 63 |
| Launching the App & Demo Mode..... | 66 |
| Getting Started..... | 67 |
| SERVICE & MAINTENANCE | 71 |
| Battery Replacement | 71 |
| i-Pilot Software..... | 72 |
| Pairing a Remote with a Controller | 73 |
| Talon Control | 75 |
| General Maintenance | 77 |
| Troubleshooting..... | 78 |
| COMPLIANCE STATEMENTS | 79 |
| PARTS DIAGRAM & PARTS LIST | 81 |
| NOTES | 85 |

SAFETY CONSIDERATIONS

Please thoroughly read the user manual. Follow all instructions and heed all safety and cautionary notices. Use of this product is only permitted for persons that have read and understood these user instructions. Minors may use this product only under adult supervision.

WARNING

You are responsible for the safe and prudent operation of your vessel. We have designed your Minn Kota product to be an accurate and reliable tool that will enhance boat operation and improve your ability to catch fish. This product does not relieve you from the responsibility for safe operation of your boat. You must avoid hazards to navigation and always maintain a permanent watch so you can respond to situations as they develop. You must always be prepared to regain manual control of your boat. Learn to operate your Minn Kota product in an area free from hazards and obstacles.

CAUTION

This unit uses a magnetic compass to detect direction of travel. The compass can be adversely affected by magnets or large, ferrous metal objects near (within 24" of) the trolling motor control head.

Obstructions on the propeller may cause excessive vibration of the motor head. This vibration can cause the compass to wander and erratic steering to occur. Clear the obstruction to return the motor to normal operation.

WARNING

It is recommended to only use Johnson Outdoors approved accessories with your Minn Kota motor, such as this i-Pilot system. Using non-approved accessories including to mount or control your motor may cause damage, unexpected motor operation and injury. Be sure to use the product and approved accessories, including remotes, safely and in the manner directed to avoid accidental or unexpected motor operation. Keep all factory installed parts in place including motor and accessory covers, enclosures and guards.

WARNING

When the motor is being controlled by the i-Pilot navigation system, the Controller will continue to perform the last task it was assigned, even when the remote is not powered on. Be sure to know how to power the motor "on" and "off", and always be alert for unexpected motor movement, such as a turning propeller, even when the remote is powered "off". Refer to the Owner's Manual for how to control the motor without the i-Pilot remote and become familiar with it's features including how to turn it "on" and "off".

WARRANTY

WARRANTY ON MINN KOTA I-PILOT® AND I-PILOT® LINK™ WIRELESS GPS TROLLING SYSTEM ACCESSORY

Johnson Outdoors Marine Electronics, Inc. ("JOME") extends the following limited warranty to the original retail purchaser only. Warranty coverage is not transferable.

Minn Kota Limited Two-Year Warranty on the Entire Product

JOME warrants to the original retail purchaser only that the purchaser's new Minn Kota i-Pilot® or i-Pilot® Link™ Wireless GPS Trolling System Accessory will be materially free from defects in materials and workmanship appearing within two (2) years after the date of purchase. JOME will (at its option) either repair or replace, free of charge, any parts found by JOME to be defective during the term of this warranty. Such repair, or replacement shall be the sole and exclusive liability of JOME and the sole and exclusive remedy of the purchaser for breach of this warranty.

Exclusions & Limitations

This limited warranty does not apply to products that have been used commercially or for rental purposes. This limited warranty does not cover normal wear and tear, blemishes that do not affect the operation of the product, or damage caused by accidents, abuse, alteration, modification, shipping damages, negligence of the user or misuse, improper or insufficient care or maintenance. **DAMAGE CAUSED BY THE USE OF OTHER REPLACEMENT PARTS NOT MEETING THE DESIGN SPECIFICATIONS OF THE ORIGINAL PARTS WILL NOT BE COVERED BY THIS LIMITED WARRANTY.** The cost of normal maintenance or replacement parts which are not in breach of the limited warranty are the responsibility of the purchaser. Prior to using products, the purchaser shall determine the suitability of the products for the intended use and assumes all related risk and liability. Any assistance JOME provides to or procures for the purchaser outside the terms, limitations or exclusions of this limited warranty will not constitute a waiver of the terms, limitations or exclusions, nor will such assistance extend or revive the warranty. JOME will not reimburse the purchaser for any expenses incurred by the purchaser in repairing, correcting or replacing any defective products or parts, except those incurred with JOME's prior written permission. **JOME'S AGGREGATE LIABILITY WITH RESPECT TO COVERED PRODUCTS IS LIMITED TO AN AMOUNT EQUAL TO THE PURCHASER'S ORIGINAL PURCHASE PRICE PAID FOR SUCH PRODUCT.**

How To Obtain Warranty Service

To obtain warranty service in the U.S., the product believed to be defective, and proof of original purchase (including the date of purchase), must be presented to Minn Kota's factory service center in Mankato, MN. Any charges incurred for service calls, transportation or shipping/freight to/from the factory, labor to haul out, remove, re-install or re-rig products removed for warranty service, or any other similar items are the sole and exclusive responsibility of the purchaser. Products purchased outside of the U.S. must be returned prepaid with proof of purchase (including the date of purchase and serial number) to any Authorized Minn Kota Service Center in the country of purchase. Warranty service can be arranged by contacting the factory at 1-800-227-6433 or email service@minnkotamotors.com. **Products repaired or replaced will be warranted for the remainder of the original warranty period [or for 90 days from the date of repair or replacement, whichever is longer]. For any product that is returned for warranty service that JOME finds to be not covered by or not in breach of this limited warranty, there will be a billing for services rendered at the prevailing posted labor rate and for a minimum of at least one hour.**

NOTICE: Do not return your Minn Kota product to your retailer. Your retailer is not authorized to repair or replace products.

NOTICE: THERE ARE NO EXPRESS WARRANTIES OTHER THAN THESE LIMITED WARRANTIES. IN NO EVENT SHALL ANY IMPLIED WARRANTIES INCLUDING ANY IMPLIED WARRANTIES OF MERCHANTABILITY OR FITNESS FOR PARTICULAR PURPOSE, EXTEND BEYOND THE DURATION OF THE RELEVANT EXPRESS LIMITED WARRANTY. IN NO EVENT SHALL JOME BE LIABLE FOR PUNITIVE, INDIRECT, INCIDENTAL, CONSEQUENTIAL OR SPECIAL DAMAGES. Without limiting the foregoing, JOME assumes no responsibility for loss of use of product, loss of time, inconvenience or other damage.

Some states do not allow limitations on how long an implied warranty lasts or the exclusion or limitation of incidental or consequential damages, so the above limitations and/or exclusions may not apply to you. This warranty gives you specific legal rights and you may also have other legal rights which vary from state to state.

FEATURES

i-PILOT REMOTE

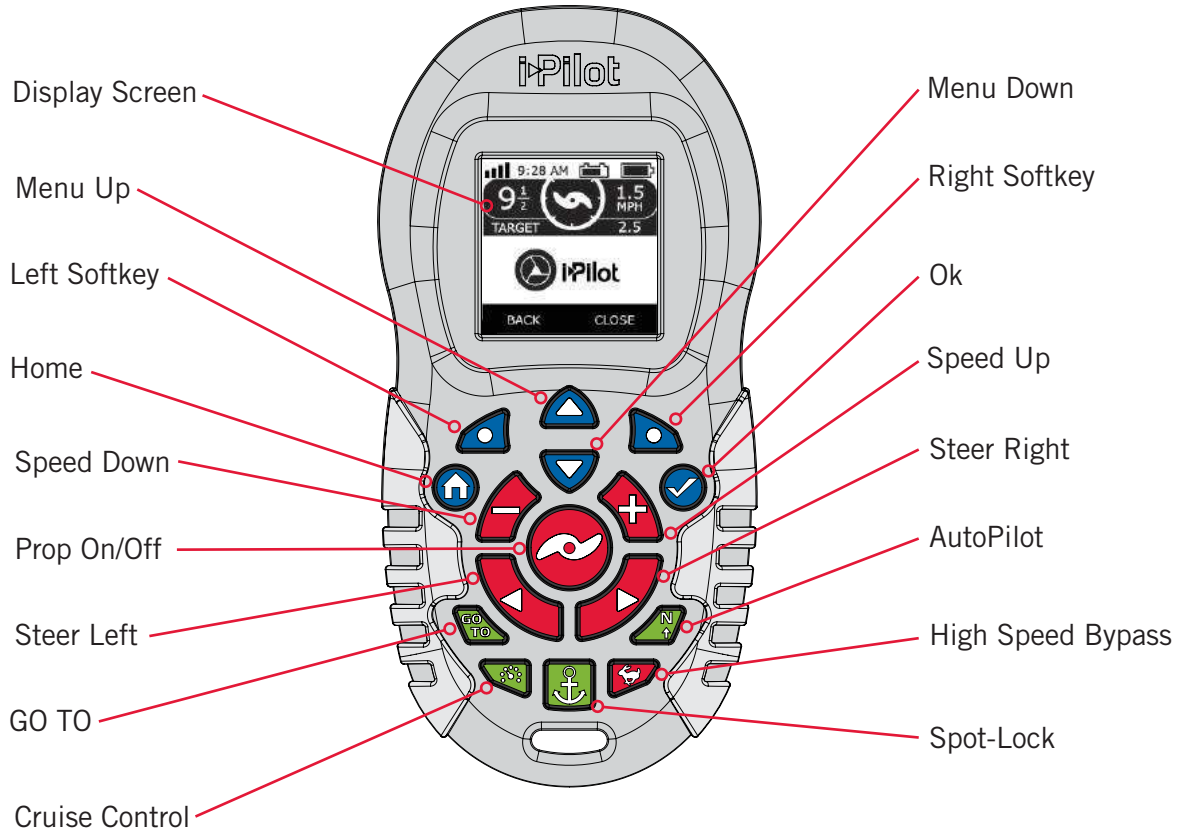

i-PILOT CONTROL HEAD

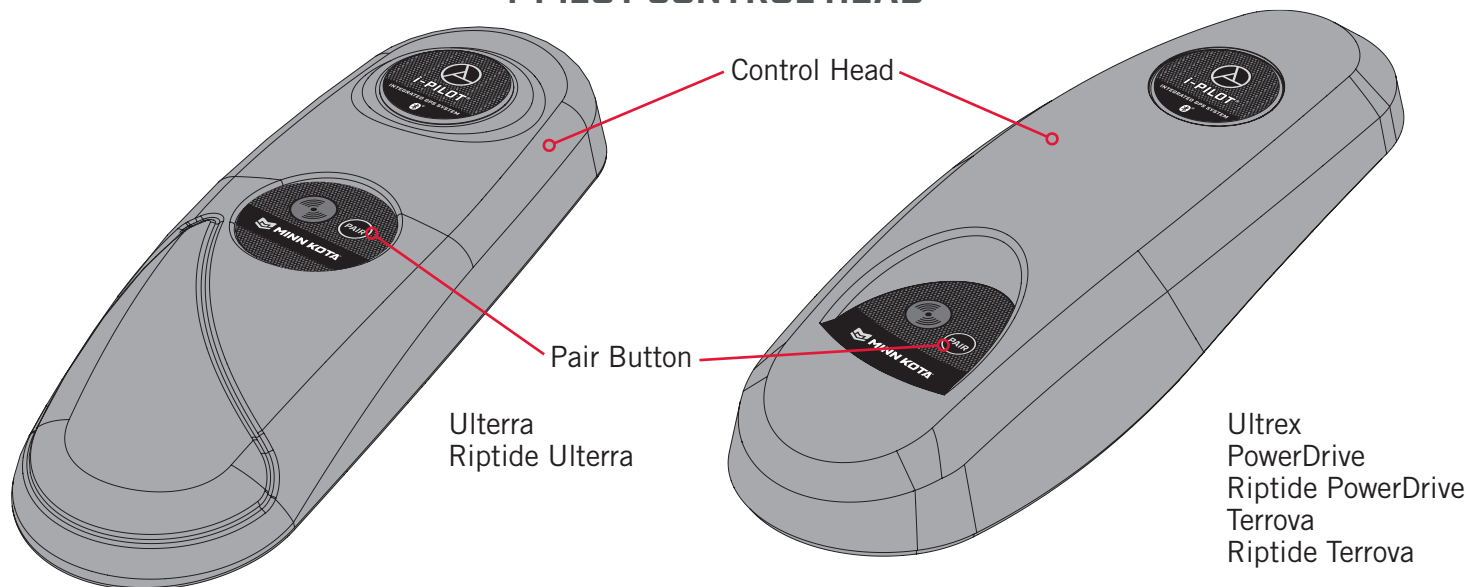

NOTICE: Specifications subject to change without notice. This diagram is for reference only and may differ from your actual product.

REMOTE BUTTONS

MENU CONTROL BUTTONS >



Home

Pressing this button will always bring you to the Home Screen.



Ok

Press to accept menu selections. Press to power remote on. Press and hold for 3 seconds to power remote off.



Left Softkey & Right Softkey

Buttons change function based on the mode of operation and which screen is presently displayed. Softkey labels at the bottom of the display screen indicate current function.



Menu Up & Menu Down

Used to navigate softkey labels and menus.

NOTICE: The remote is waterproof, but will not float.

MANUAL CONTROL BUTTONS >



Speed Down & Speed Up

Press to increase or decrease motor speed.



Prop On/Off

Pressing this button will turn the Prop on and off.





Steer Left & Steer Right





Press to steer the motor to the left or to the right.



High Speed Bypass

Bypasses the current motor speed to speed 10. Quickly double press to engage. Single press to disengage.

NOTICE: If Steer Right  or Steer Left  is held down for more the six to eight seconds, the steering will stop to prevent the coil cord from wrapping around the shaft on some models.

NOTICE: If your motor is connected to a Heading Sensor, the Speed Down  (backwards), Speed Up  (forward), Steer Right  and Steer Left  buttons function change to Jog the boat while in Spot-Lock.

NAVIGATION BUTTONS >



GO TO

Opens the list of Spot-Locks and iTracks that are within navigable range.



Cruise Control

Press to enable Cruise Control.



Spot-Lock

Press to enable Spot-Lock.



AutoPilot

Press to enable AutoPilot.

HEADER & ICONOGRAPHY

HEADER >

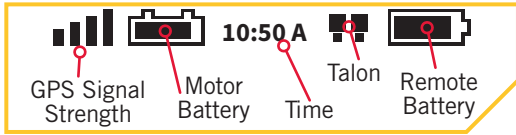

GPS Signal Strength
Shows the level of GPS signal strength. If no bars appear, the system has not yet acquired a GPS fix.

Motor Battery ◆
Displays motor battery level when prop is disengaged.

10:50 A Time
Displays the current time.

Remote Battery
Displays the battery level of the remote.

Talon
Displays the connection with one or two Talons and indicates if the Talon(s) are deployed.

ICONOGRAPHY >

Spot-Lock
Displays when Spot-Lock is engaged.

Spot-Lock Jog
Displays when Spot-Lock is engaged and the motor is communicating with a Heading Sensor.

Legacy AutoPilot
Displays when AutoPilot is engaged and the AutoPilot Mode is set to Legacy.

Advanced AutoPilot
Displays when AutoPilot is engaged and the AutoPilot Mode is set to Advanced.

Record
Displays when an iTrack is being recorded.

iTrack
Displays when an iTrack is being navigated.

Prop Lockout
Displays when the Prop is locked-out during certain functions.

Trim ◆
Displays when Trim is being adjusted.

Brightness
Displays when screen brightness is being adjusted.

Talon Selection
Displays the active Talon as either left, right or both.

Prop
Displays when the Prop is enabled. Rotates when the Prop is on and the Prop Speed is greater than zero. Blinks when a mode of navigation is used that requires the prop to be enabled.

10 Prop Speed
Displays the current Prop Speed. Can be adjusted in 1/2 speed increments between 0 and 10.

0.7 mph Ground Speed
Displays the current speed over ground.

TARGET 1.5 Cruise Control
Displays the Target Speed when Cruise Control is engaged.

Lock
Displays when the Remote is locked.

Scroll Up & Down
Displays when the softkey labels at the bottom of the display screen have more options available.

◆ Only available with Ultrerra.

■ Only available with Ultrex.

DISPLAY SCREEN

SAMPLE SCREENS >

Become familiar with some of the display screens used on the i-Pilot remote interface.

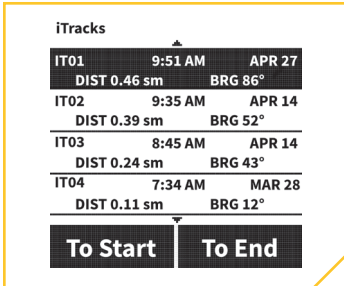

A list of iTracks that are in navigable range. The date and time listed are generated when the track is recorded.

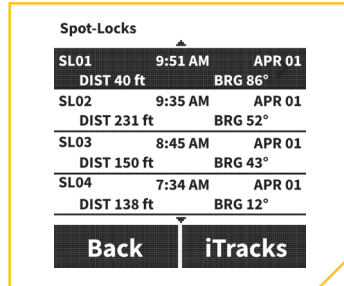

A list of Spot-Locks that are in navigable range. The date and time listed are generated when the Spot-Lock is saved.

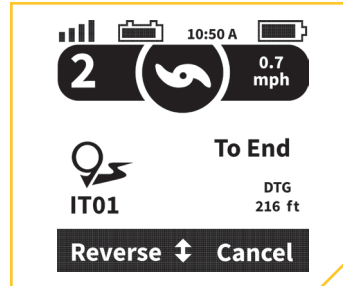

Navigating an iTrack when the boat is on course to go to the end of the iTrack.

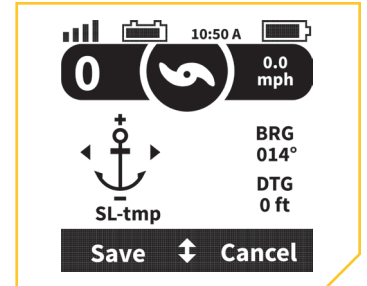

A temporary Spot-Lock created when the Spot-Lock button is pressed and Spot-Lock Jog is available.

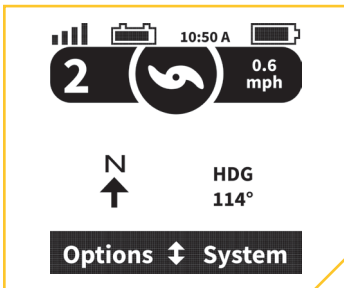

Navigating with Legacy AutoPilot.

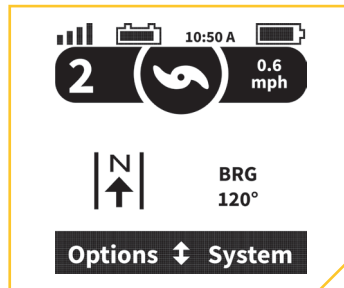

Navigating with Advanced AutoPilot.

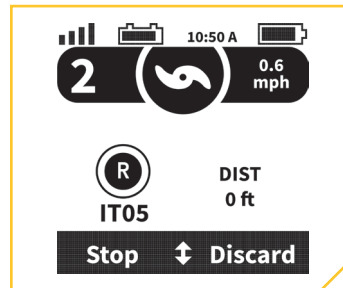

Recording an iTrack.

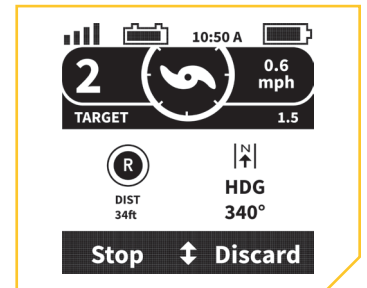

Recording as iTrack while in Advanced AutoPilot.

TERMS & ABBREVIATIONS >

Become familiar with common terms and abbreviations in order to understand what the remote is communicating about runtime navigational data.

To Start To Start

When recording or navigating an iTrack, the To Start location is the beginning of the iTrack.

To End To End

When recording or navigating an iTrack, the To End location is the end of the iTrack.

DTG Distance To Go

When Navigating to a Spot-Lock it is the distance left before the destination is reached. When navigating an iTrack it is the distance to go to reach either the To Start or To End location on the iTrack depending on which direction the iTrack is being navigated.

DIST Distance

Distance from the boat's current location to a Spot-Lock or the boat's location and closest point on an iTrack.

BRG Bearing

Bearing is the direction from the boat's current location to the target destination. A target destination can be a Spot-Lock or iTrack.

HDG Heading

Heading is the direction that the motor is pointing or traveling.

GETTING STARTED

THE i-PILOT SYSTEM

The i-Pilot navigation system comes pre-installed on your trolling motor. If your motor comes with a Heading Sensor, the Heading Sensor needs to be installed and paired with the i-Pilot controller. The i-Pilot controller is contained in the motor Control Head. Please see the "Heading Sensor" portion of this manual for more information on the Heading Sensor. The i-Pilot remote also comes paired to the controller from the factory. The i-Pilot remote and controller make up the i-Pilot navigation system. The top of the motor Control Head also has a single pair button to allow additional remotes and the Heading Sensor to be paired to the system. A remote can only be paired with one controller at a time. The i-Pilot controller contains a very sensitive compass and is where all GPS satellite and i-Pilot remote signals are received. Before each startup, it is recommended to inspect the Remote, Propeller, and Control Head for damage and to make sure that there are no obstructions that would affect communication between the Control Head, the GPS signal and the Remote, or boat movement.

NOTICE: It is very important that the controller have a clear view of the sky in all directions and has a clear line of sight to the remote for optimum performance.

› Power

The i-Pilot controller will turn on whenever the trolling motor has power. Refer to the Owner's Manual for your specific motor to determine how to power up your trolling motor. Owner's Manuals can be found on-line at minnkotamotors.com. It is recommended to turn off and disconnect the power source from the trolling motor when not in use.

› Accuracy

The accuracy and responsiveness with which i-Pilot controls your boat is highly dependent upon many variables. Just a few of these variables and their general effects on responsiveness and accuracy are given below so that the behavior of the system can be understood.

⚠ CAUTION

This unit uses a magnetic compass to detect direction of travel. The compass can be adversely affected by magnets or large, ferrous metal objects near (within 24" of) the trolling motor control head.

Obstructions on the propeller may cause excessive vibration of the motor head. This vibration can cause the compass to wander and erratic steering to occur. Clear the obstruction to return the motor to normal operation.

Power should be disconnected from the motor when not in use. Removing the motor from the power source will ensure that current is not reaching the electronics when not in use.

| Variable | Effect |
|--------------------------------------|--|
| Ratio of motor thrust to boat weight | Excessive thrust on a smaller boat can cause i-Pilot to over correct. Not enough thrust on a large boat can cause i-Pilot to respond slowly. |
| Wind | Excessive wind and/or current can reduce i-Pilot's positioning accuracy. |
| GPS signal strength | The greater number of GPS signal bars the greater the accuracy. |
| Trolling motor battery power level | A fully charged battery will give the best performance. |

› Navigation

i-Pilot uses GPS satellite signals as well as compass data to know where it is, where its heading and the direction the motor is pointing. Since i-Pilot depends on GPS satellite signals for navigation, a minimum GPS signal of one bar is required in order for GPS navigation controls to be enabled. Best results are achieved when GPS signals of four bars can be obtained.

i-Pilot also uses a method of GPS navigation called Arrival Circles. These imaginary circles allow i-Pilot to understand when it has drifted away from a point and when it has arrived at a point. The size of the circle varies depending on signal strength. The greater the signal strength the smaller the Arrival Circle.

› Range

The range of the remote will be greatly reduced if it is used near or mounted to any metal object including aluminum or steel. It is also recommended that the front end of the remote not be obstructed during use.

› Battery

The Remote is powered by three Alkaline AAA batteries. It is recommended to always use this type of battery to get the best performance and battery life. By default, the remote will automatically turn itself off thirty minutes after the last button press.

NOTICE: Remote battery life is subject to frequency of use and is especially impacted by how often and bright the LCD backlight is used.

⚠ CAUTION

Fluctuating temperatures can lead to battery damage, such as capacity loss, leakage or rupture of batteries. Damaged batteries may damage your remote. Minn Kota recommends removing batteries from the remote when it is not expected to be used for extended periods of time, or for long-term storage, to avoid remote damage from the batteries.

SYSTEM STARTUP ›

Follow these simple steps each time you power up your trolling motor for successful operation:

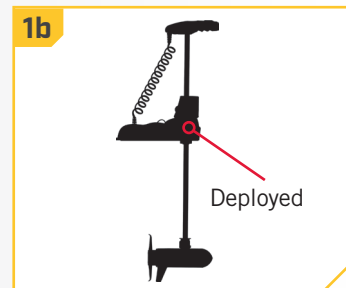
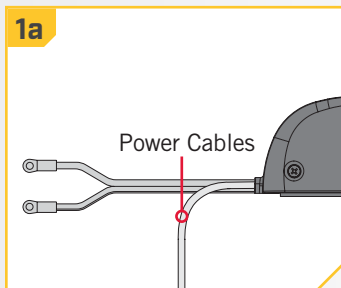

- 1
 - a. Connect trolling motor to power.
 - b. Deploy trolling motor into water.

NOTICE: i-Pilot startup varies slightly between trolling motor models. The Ulterra i-Pilot controller, in the Control Head, can communicate with the remote when the motor is stowed, once the motor and remote have power.









GETTING STARTED

2

- c. Push the Ok  button on your remote. The display screen will turn on. A message about i-Pilot operation will appear on the display screen. Use the Right Softkey  to select OK.
- d. The display screen will then show the Home Screen.

NOTICE: The Home Screen will vary slightly in appearance based on motor model and factory default selections.

- e. You are now able to use all manual functions in the remote including Speed Up , Speed Down , Steer Left , Steer Right , Prop On/Off , and High Speed Bypass .
- f. After i-Pilot has obtained a minimum GPS signal strength of one bar, all remaining functions will become available.

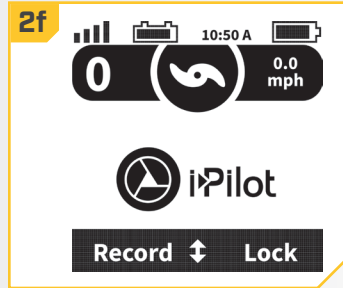
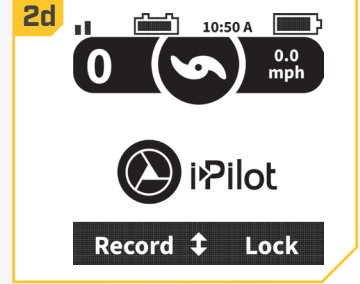
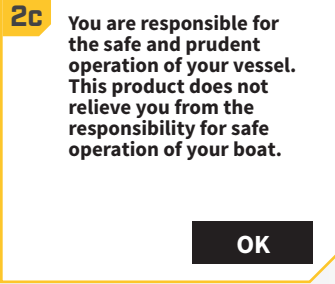

AUDIO MODES



AUDIO MODES

The i-Pilot controller in the Control Head contains an internal speaker which can be configured to work in two different audio modes. The unit is factory set to Audio Mode 2. Review the modes below to determine what audio patterns are caused by conditions in each audio mode.

| Audio Pattern | What Condition Causes Audio Pattern | Audio Mode |
|------------------------------|--|---------------|
| Error | Attempting to enable a GPS feature when no signal strength bars are shown. | Mode 2 |
| | Attempting to replay an iTrack or recall a Spot-Lock location when the boat is beyond the minimum required distance. | Mode 2 |
| | The Momentary Button on the foot pedal is pressed, for applicable motors, and a remote button press attempts to override it. | Mode 2 |
| | When GPS signal strength goes to no bars while in a GPS-based mode. | Mode 2 |
| | When overriding navigation by steering with the foot pedal or remote. | Modes 1 and 2 |
| Single Beep | Speed + (When less than maximum speed.) | Mode 2 |
| | Speed - (When greater than speed 0.) | Mode 2 |
| | Enable High Speed Bypass. | Mode 2 |
| | Switch to Audio Mode 1 | Modes 1 and 2 |
| | Manual Prop on | Mode 2 |
| | Enabling or disabling Record, GO TO, AutoPilot, Cruise Control or Spot-Lock. | Mode 2 |
| Double Beep | Disable High Speed Bypass. | Mode 2 |
| | Switch to Audio Mode 2 | Modes 1 and 2 |
| | Manual Prop off | Mode 2 |
| 3 longer Beeps | Pair successfully completed | Modes 1 and 2 |
| 4 Short Beeps | Startup | Modes 1 and 2 |
| Steady Tone | Pair button is pressed. | Modes 1 and 2 |
| High-Low, High-Low, High-Low | End of iTrack attained during track playback (in conjunction with canceling mode and turning the prop off) | Mode 2 |

AUDIO MODE CONTROL >





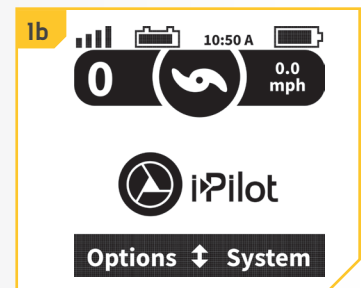
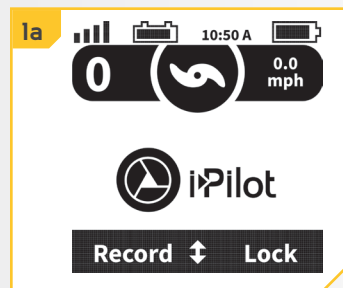

> Changing the Audio Mode

- 1
 - a. Press the Home  button.
 - b. Use the Menu Up  and Menu Down  buttons to find the Options menu at the bottom of the display screen.



AUDIO MODES

2

- c. Use the Left Softkey  to select the Options menu.
- d. Use the Menu Up  and Menu Down  buttons to find the Audio Mode menu. Use the Ok  button to select it.
- e. Use the Menu Up  and Menu Down  buttons to scroll to the desired Audio Mode. Use the Ok  button to select it.

NOTICE: When Audio Mode 1 is selected, the Control Head will emit one beep. When Audio Mode 2 is selected, the Control Head will emit two beeps.

- f. Use the Right Softkey  to close the menu.

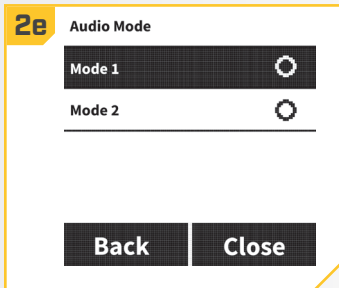
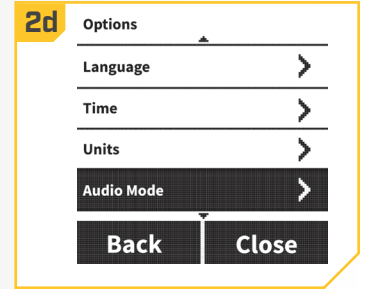
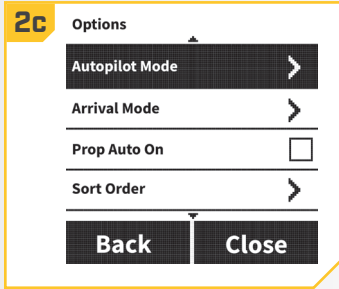

SPOT-LOCK

HOW SPOT-LOCK WORKS



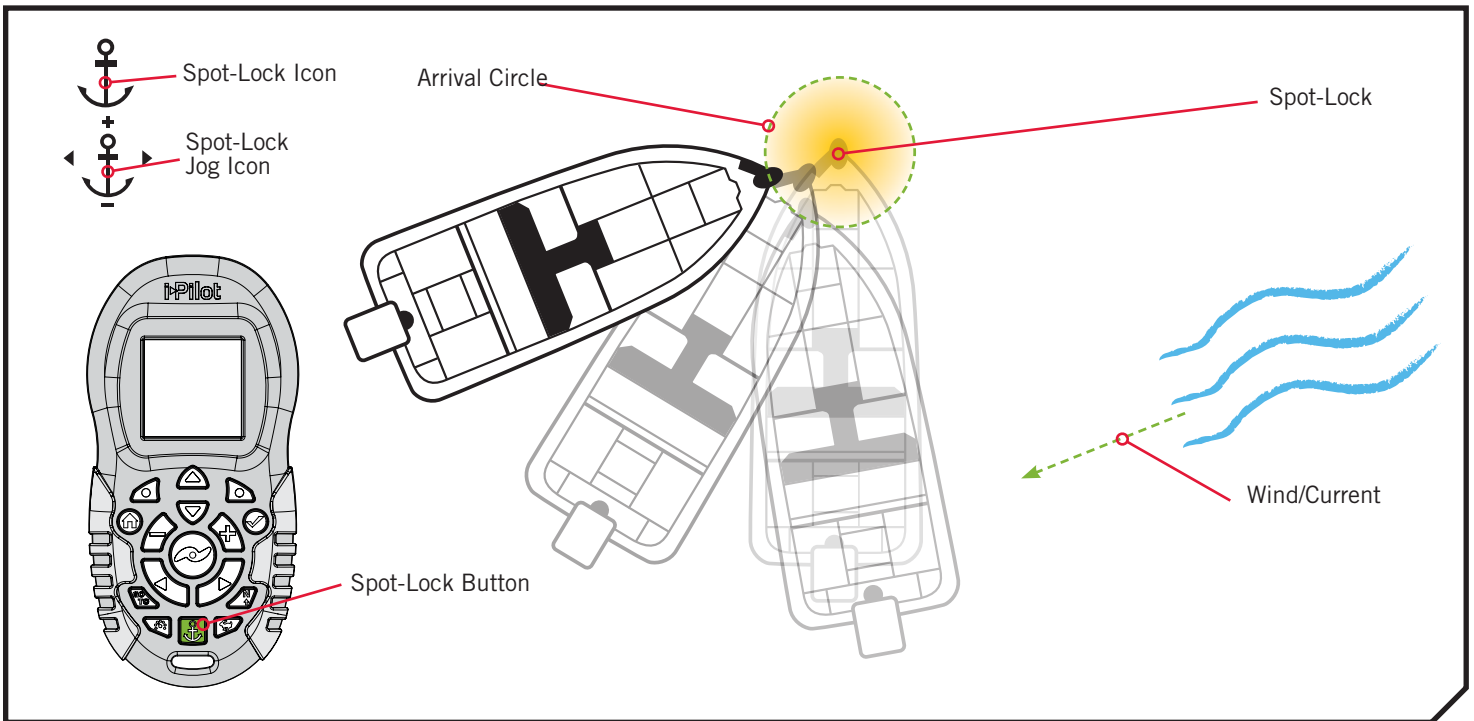

Spot-Lock uses a single point of reference that is recorded when the Spot-Lock button is pressed. The reference point is a set of GPS coordinates based on the location of the motor at the moment the button is pressed. This point is recorded and can be saved into one of the Spot-Lock memory locations. Spot-Lock works by creating an Arrival Circle around the Spot-Lock that the motor will automatically navigate to and try to stay within. Spot-Lock engages the motor to keep it in the Arrival Circle around the Spot-Lock location. If i-Pilot sees the motor is within the Arrival Circle, it will adjust the motor speed to zero. If i-Pilot sees the motor is outside of the circle, it will control motor speed and direction in an attempt to get the boat back into the Arrival Circle.

NOTICE: Spot-Lock is based on the location of the motor, not on the location or direction of the boat. Outside forces such as wind and current will cause the boat to move around the Arrival Circle. Spot-Lock will navigate to maintain the motor within the Arrival Circle regardless of the position of the boat.



SPOT-LOCK FUNCTIONS >

> Engaging Spot-Lock

- 1 a. Press the Spot-Lock  button on the remote.
b. The information for the temporary Spot-Lock location will show up on the display screen. Use the Menu Up  and Menu Down  buttons to find the Save softkey label at the bottom of the display screen. To save the Spot-Lock, press the Left Softkey  to open the Save menu.

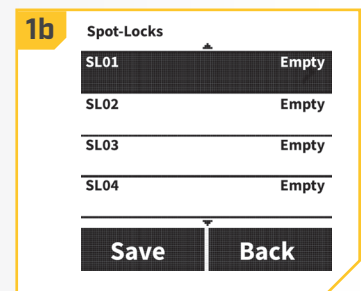
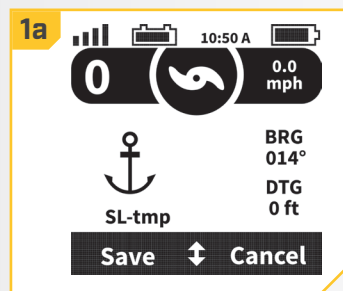

2

- c. The Save menu brings up a list of Spot-Locks. Use the Menu Up and Menu Down buttons to select one of the Spot-Lock memory locations.
- d. Press the Left Softkey to Save the Spot-Lock into the selected menu location. Press the Right Softkey to go Back to the previous screen.

NOTICE: If the Spot-Lock button is accidentally pressed, press the Spot-Lock button again or press the Right Softkey to select Cancel from the menu to escape Spot-Lock.

NOTICE: 16 Spot-Lock memory locations may be recorded.

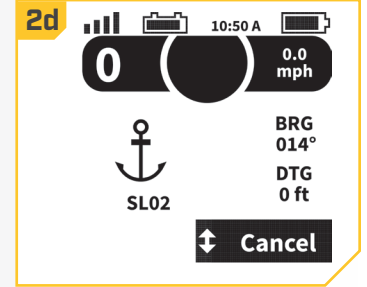
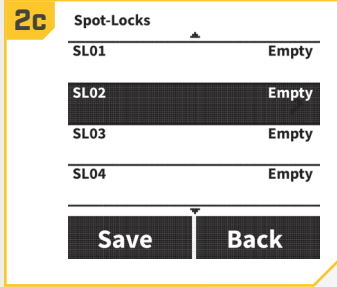

NOTICE: If a Spot-Lock is already saved to a Spot-Lock memory location, it will automatically overwrite previously saved data for that memory location when you select Save. Once a new Spot-Lock is saved into memory, the previous Spot-Lock cannot be recalled.

Disengaging Spot-Lock

1

- a. When Spot-Lock is engaged, press the Spot-Lock button to disengage Spot-Lock, or use the Menu Up and Menu Down buttons to find the Cancel softkey label at the bottom of the display screen.
- b. Use the Right Softkey to select Cancel.

NOTICE: If your motor is equipped with a foot pedal, pressing any motor control button on the foot pedal will disengage Spot-Lock.

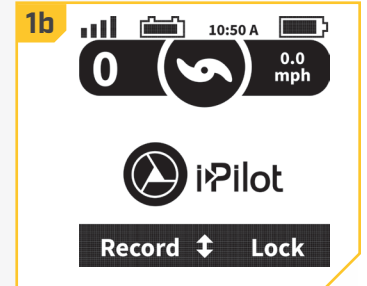
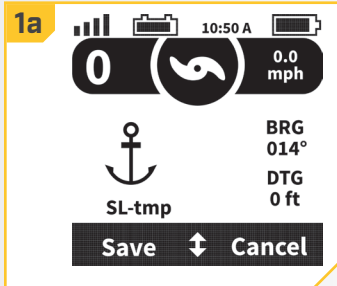

Re-engage a Saved Spot-Lock

1



- a. Manually navigate the boat to within a quarter mile of the saved Spot-Lock location.
- b. Press the GOTO button on the remote.

WARNING

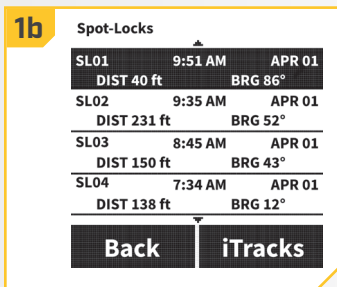
Due to safety reasons, i-Pilot will not re-engage a saved Spot-Lock location greater than a quarter mile away.



2



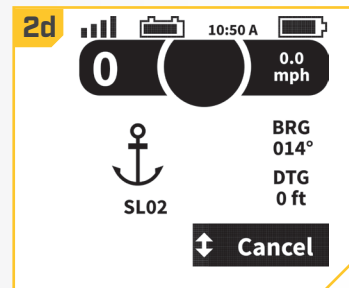
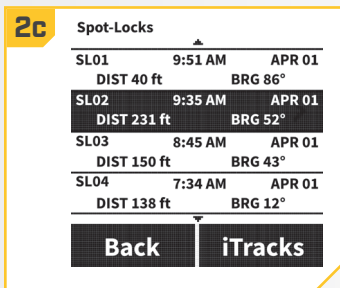





- c. The Spot-Locks menu will appear on the display screen. Use the Menu Up  and Menu Down  buttons to scroll to a saved Spot-Lock location in the menu.
- d. Press the Ok  button to select a saved Spot-Lock location.



Spot-Lock Jog

Spot-Lock Jog is a feature that is only available when the i-Pilot controller is paired with a Heading Sensor. For information on the Heading Sensor, go to the "Heading Sensor" section of this manual.

1

- a. To engage Spot-Lock Jog, first engage Spot-Lock. The Spot-Lock Jog icon will look like the Spot-Lock icon, but will also have directional indicators.
- b. Use the Speed Down , Speed Up , Steer Left , Steer Right , buttons to move the boat 5 feet in the desired direction from the original Spot-Lock.
- c. The boat will be moved backwards for Speed Down , forward for Speed Up , left for Steer Left , and right for Steer Right , when the corresponding button is pressed in relation to the direction of the boat. Once the boat has jogged to the new location, the new location will be saved into a temporary Spot-Lock Memory and the boat will relate additional jogging with the temporary Spot-Lock location.

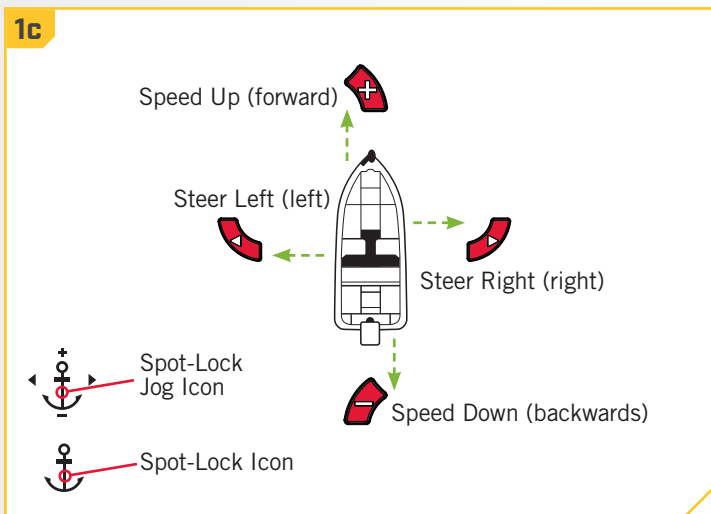
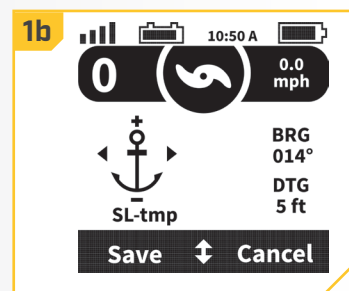
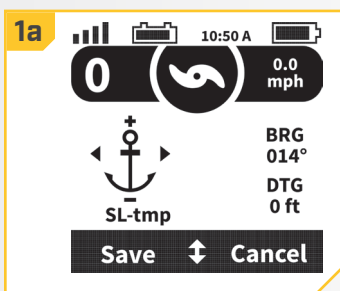

NOTICE: A Heading Sensor is required for Spot-Lock Jog. If your motor is not paired with a Heading Sensor, the Spot-Lock icon will appear without the directional indicators and the option to jog will not be available.

NOTICE: Spot-Lock Jog moves the GPS coordinates of the Spot-Lock location based on the orientation of the boat as determined by communication with the Heading Sensor. The Spot-Lock location can be jogged multiple times consecutively. Once the Spot-Lock location has been jogged, the i-Pilot navigational system will recognize the new Spot-Lock location, and i-Pilot will control the motor to move the boat accordingly.

CRUISE CONTROL

i-PILOT WITH CRUISE CONTROL

During regular operation of the i-Pilot navigational system, the user can control prop speed. The controller will communicate the speed over ground to the remote and the remote will display it. The speed over ground is the speed that the boat is traveling and will vary based on environmental factors such as wind and current, even if the prop speed remains the same. Cruise Control helps to compensate for the variations in external forces that effect the speed over ground and keeps the boat traveling at an even speed. When Cruise Control is engaged, the current speed over ground becomes the Target Speed. Cruise Control works to control the prop speed either up or down to match the speed over ground to the Target Speed.

WARNING

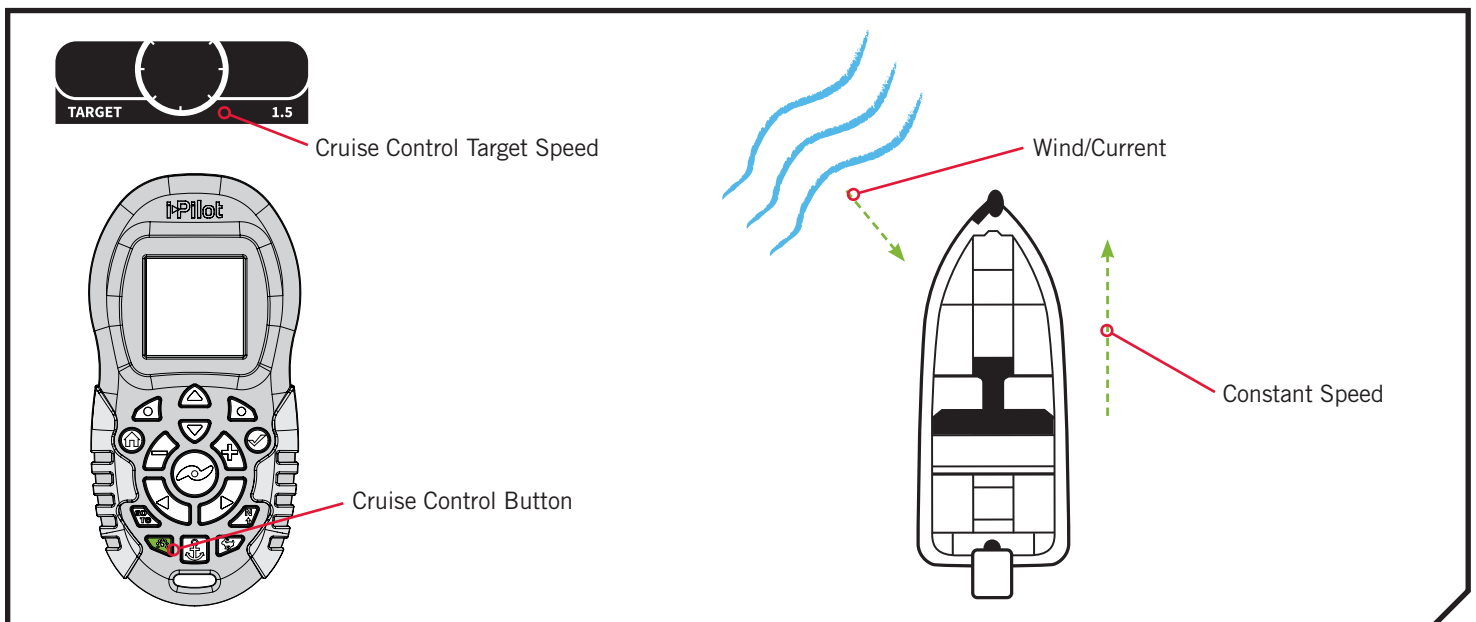

Watch for turning propeller when Cruise Control is engaged. The propeller will automatically turn on when Cruise Control is engaged, even if the engagements is accidental. A turning propeller can cause injury. Be mindful of the prop when engaging Cruise Control to prevent injury. The propeller will turn on regardless of the Auto Prop On setting. If the propeller is not "on" before the Cruise Control is engaged, it will be turned "on", or enabled and run at the current speed setting.



WORKING WITH CRUISE CONTROL >

> Engaging Cruise Control

1

- a. Press the Cruise Control  button on the remote.
- b. The Target Speed will appear on the display screen. Press the Speed Down  or Speed Up  buttons to adjust the Target Speed.

NOTICE: If the Prop is not turning, be sure to press the Prop Button  to enable it. The Prop Auto On setting does not affect Cruise Control.

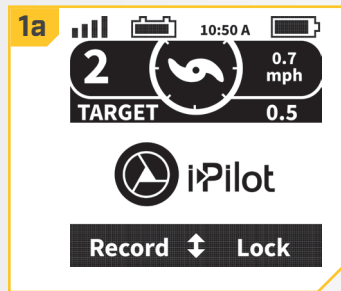

> Disengaging Cruise Control





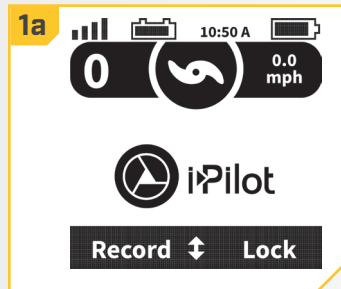

1



- a. When Cruise Control is engaged, press the Cruise Control  button on the remote to disengage Cruise Control.



› Jump To or Set a Cruise Control Preset

1

- a. To jump to or set a Cruise Control Preset, first engage Cruise Control.
- b. Use the Speed Down  or Speed Up  buttons to change the Target Speed. While adjusting the Target Speed, the menu at the bottom of the display screen temporarily changes to display two Preset Target Speeds.
- c. While the Presets are showing, press either the Left Softkey  or Right Softkey  to jump to the corresponding Preset on the display screen.
- d. To save the Preset to a new value, adjust the Target Speed to the desired value. While the Presets are showing in the menu at the bottom of the display screen, press and hold either the Left Softkey  or Right Softkey .

NOTICE: The Left Softkey  will jump to or save the Preset Target Speed displayed on the left side of the menu that appears. The Right Softkey  will jump to or save the Preset Target Speed displayed on the right. Once saved, a message will flash on the screen stating "Preset Saved" and then disappear.

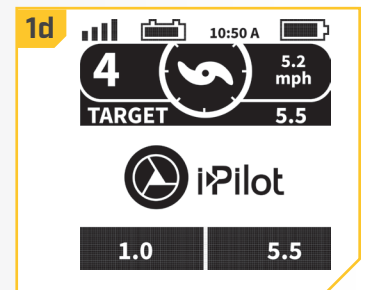
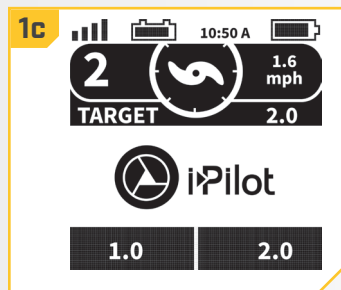
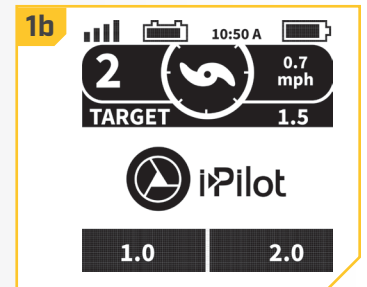
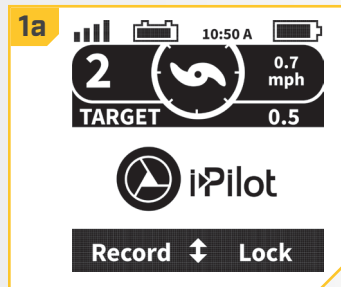

HIGH SPEED BYPASS

MOTOR SPEED AND HIGH SPEED BYPASS

The Motor Speed with High Speed Bypass is set to 10 when engaged and returns to the previously set speed when disengaged.

WARNING

Watch for a turning propeller when High Speed Bypass is engaged. A turning propeller can cause injury. High Speed Bypass will automatically turn the prop on to Speed 10, even if the engagement is accidental.

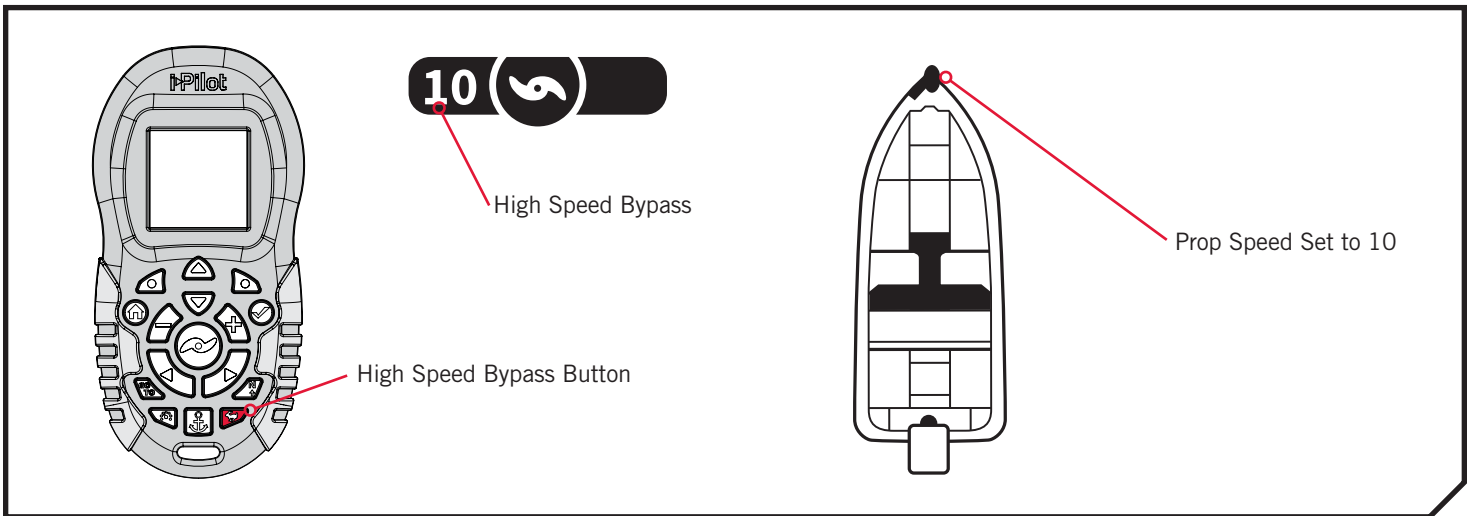

CONTROLLING HIGH SPEED BYPASS >

> Engaging High Speed Bypass

- 1 a. Quickly double press the High Speed Bypass  button on the remote.

NOTICE: When engaging High Speed Bypass, quickly double press the button twice to engage. The remote will not recognize the press as a double press if the time between presses is too delayed.

- b. The Prop Speed will automatically display 10.

NOTICE: If the Prop is not turning, be sure to press the Prop Button  to enable it. The Prop Auto On setting does not affect High Speed Bypass. If High Speed Bypass is engaged and the prop is flashing, it needs to be turned "on" in order for High Speed Bypass to work.

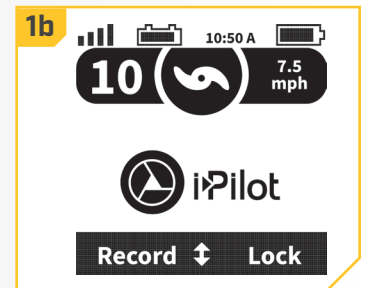
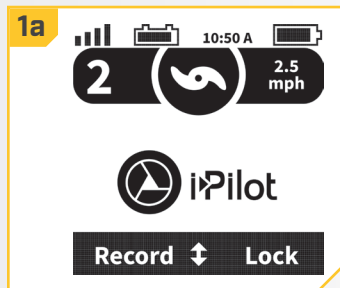

Disengaging High Speed Bypass

1

- a. When High Speed Bypass is engaged, press the High Speed Bypass  button on the remote to disengage High Speed Bypass.

NOTICE: Manually adjusting the speed below speed 10 will also disengage High Speed Bypass.

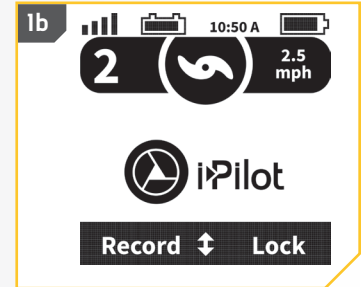
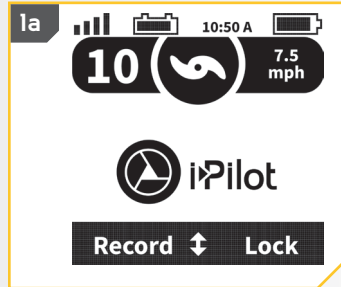

AUTOPILOT

i-PILOT WITH AUTOPILOT

When in AutoPilot, i-Pilot keeps the trolling motor pointed in the direction you want to go. Each time the wind or water current moves the boat off course, the AutoPilot senses the change and steers itself back to the original heading. The AutoPilot direction is set every time a steering change is made. To change direction, steer until the Control Head points to the desired course. AutoPilot will pull the bow of the boat around and correct automatically until the boat is moving in the direction you chose.

AUTOPILOT MODES

Two different modes of AutoPilot are available, Advanced AutoPilot and Legacy AutoPilot. Both are collectively referred to as AutoPilot. There are distinct differences between the two AutoPilot Modes and how they control your boat. Both Advanced AutoPilot and Legacy AutoPilot are valuable tools the fisherman can use for accurate and precise bait presentation. We highly recommend getting on the water and trying both Advanced AutoPilot and Legacy AutoPilot in various fishing situations and applications. With experimentation and time you will find which AutoPilot Mode works best for you in any given situation.

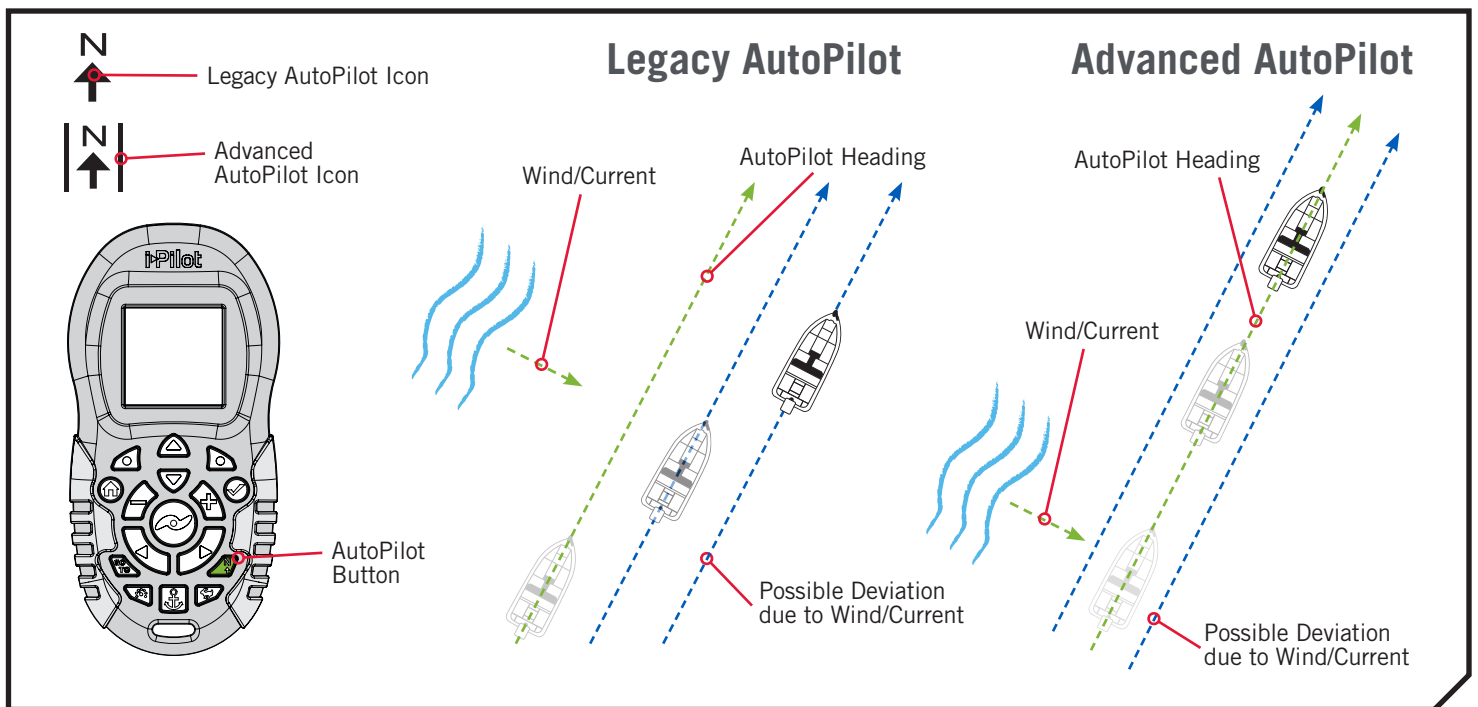

› Legacy AutoPilot

AutoPilot uses an internal compass to provide heading lock. When Legacy AutoPilot is on, it keeps the motor pointed in the same compass direction. If a manual steering correction is made, Legacy AutoPilot locks onto the new compass heading to which the boat was steered. This method of heading tracking does not take into account external forces such as a side wind or currents, which can allow side drift.

› Advanced AutoPilot

Advanced AutoPilot not only uses compass heading but also GPS data to correct for cross winds, current and other external forces to keep the boat on the intended course. When Advanced AutoPilot is turned on, it creates a course that it will follow. When the user steers to a new heading, a new course is created. Advanced AutoPilot will keep the boat on the course in most conditions. When very extreme conditions exist such as very strong winds or current, the trolling motor may not have enough power to control the boat smoothly. In these extreme cases it may be best to use Legacy AutoPilot and let the boat move with the wind or current if the motor is not powerful enough to overcome it.

WORKING WITH AUTOPILOT >

> Engaging Legacy AutoPilot or Advanced AutoPilot

- 1
 - a. Press the AutoPilot  button on the remote.
 - b. The Legacy AutoPilot or Advanced AutoPilot icon will display on the screen.
 - c. To adjust the desired heading, manually steer the motor to the new heading. i-Pilot will automatically lock onto the new heading.

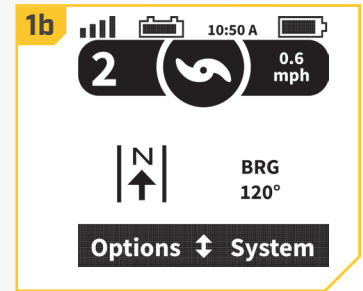
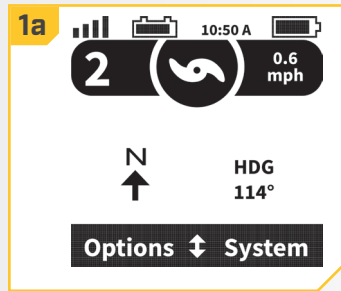

NOTICE: If the Prop is not turning, be sure to press the Prop Button  to enable it. If AutoPilot is engaged and the prop is flashing, it needs to be turned "on". The Prop behavior for AutoPilot can be changed with the Prop Auto On setting. Read "To Toggle the Prop Auto On" section of this manual for more information.

NOTICE: After steering to a new direction, there is a short delay before the direction is locked in to allow the compass to stabilize. When broad speed changes are made, the motor heading may change slightly. This is normal.

CAUTION

This unit uses a magnetic compass to detect direction of travel. The compass can be adversely affected by magnets or large, ferrous metal objects near (within 24" of) the trolling motor control head.

Obstructions on the propeller may cause excessive vibration of the motor head. This vibration can cause the compass to wander and erratic steering to occur. Clear the obstruction to return the motor to normal operation.

NOTICE: When AutoPilot is on and the trolling motor is pulled out of the water to the stow position, the steering motor will continue to run. Turn off AutoPilot to stop the motor. If AutoPilot is left on, the steering motor will shut off automatically after 8 seconds. The motor should not be stored in this condition for long periods as power is still being applied to all electronics. Always turn AutoPilot off and disconnect your motor from the battery when storing your motor.

> Disengaging Legacy AutoPilot or Advanced AutoPilot

- 1
 - a. Press the AutoPilot  button on the remote to disengage AutoPilot.

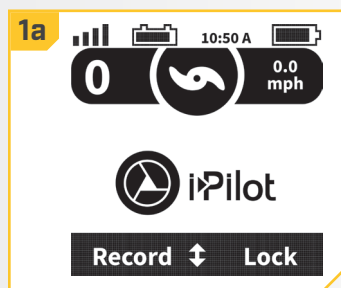







› To Set the Default AutoPilot Mode

AutoPilot has two modes:

1. Legacy - This method of heading tracking does not take into account external forces such as a side wind or currents, which can allow side drift.
2. Advanced - Advanced AutoPilot not only uses compass heading but also GPS signal data to correct for cross winds, current and other external forces to keep the boat on an intended course.



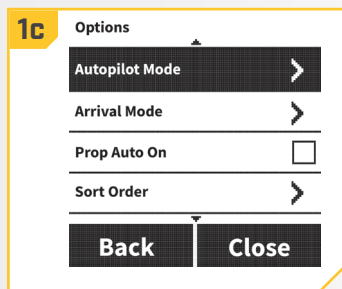
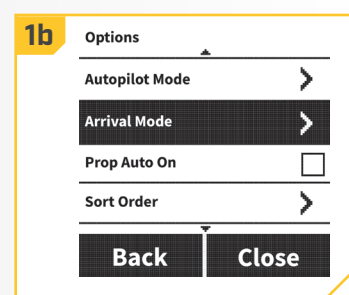
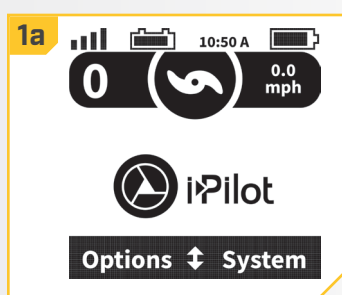

Once it is determined which AutoPilot Mode to operate in, use the following instructions to set it as the default.

1

- a. Press the Menu Up  and Menu Down  buttons until the Options Menu appears at the bottom of the display screen.
- b. Press the Left Softkey  to select the Options Menu.
- c. Press the Menu Up  and Menu Down  buttons to navigate to the AutoPilot Mode menu option.
- d. Press the Ok  button to select the AutoPilot Mode menu.



2

- e. Press the Menu Up  and Menu Down  buttons to navigate to the AutoPilot Mode desired. Use the Ok  button to select it. The circle to the right of the selected AutoPilot Mode will become solid when selected and the corresponding icon will display on the bottom of the display screen when using AutoPilot.
- f. Use the Right Softkey  to Close the AutoPilot Mode menu and return to the home screen.

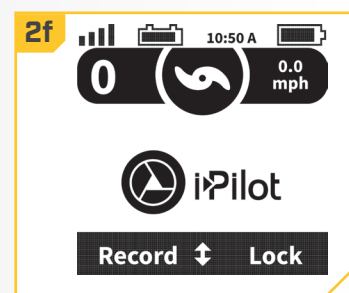
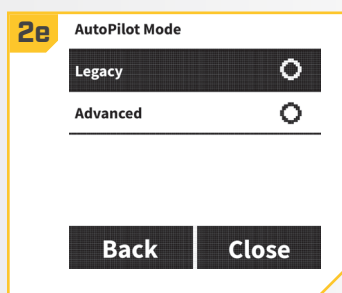

NOTICE: You can change the AutoPilot Mode while AutoPilot is engaged.

iTRACKS

UNDERSTANDING iTRACKS

The i-Pilot system can be used to record sets of points that make up an iTrack. When recording an iTrack, i-Pilot starts to record GPS position data in the form of Track Points. The very first Track Point recorded is called the Start, and the last point recorded is called the End. i-Pilot sees a recorded series of Track Points as an iTrack. iTracks can be recorded and navigated. When the GOTO Button is pressed, an iTrack can be navigated To Start or To End. i-Pilot will navigate to the nearest Track Point and then navigate to the Track Point requested. Once the nearest Track Point is reached, it will then follow the Track Points in sequence back to either the Start or End based on the selection made. Once the Start or End is reached, i-Pilot automatically transition onto the set Arrival Mode. During iTrack navigation, i-Pilot takes control over all steering functions; speed can be manually controlled or the Cruise Control function can also be used. The motor speed must be set high enough in order to stay on the track given wind, current and other external forces.

WARNING

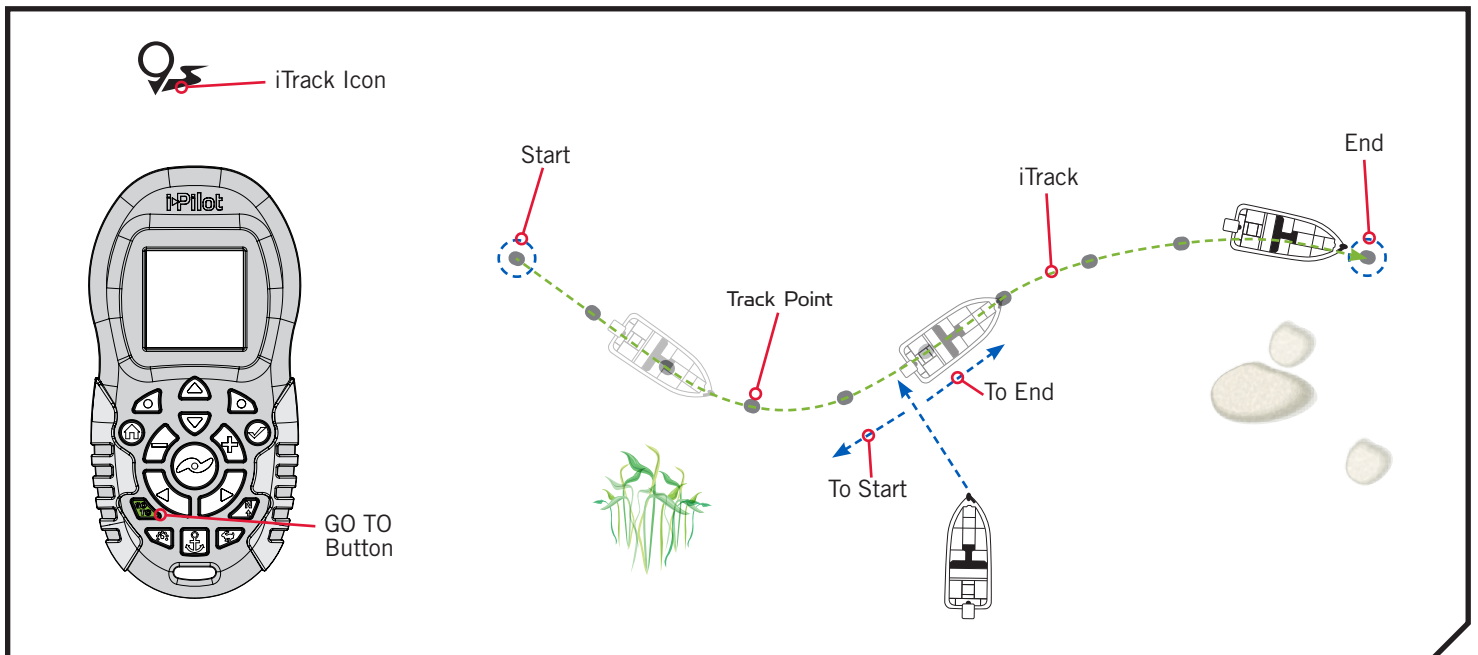

Watch for a turning propeller when working with iTracks. Auto Prop On is set to "off" by default. If Auto Prop On is turned "on", the propeller will automatically turn on when an iTrack is engaged, even if the engagement is accidental. A turning propeller can cause injury. If Auto Prop On is turned "off" the prop must be enabled before the boat will begin navigating an iTrack.



WORKING WITH ITRACKS >

> Recording an iTrack



1

- a. Use the Menu Up  or Menu Down  buttons until the menu at the bottom of the display screen shows the Record menu.
- b. Use the Left Softkey  to select the Record menu.

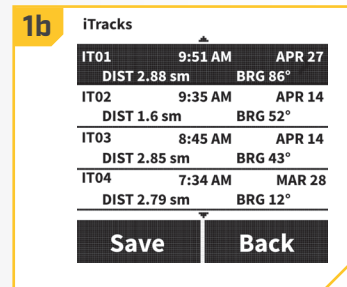
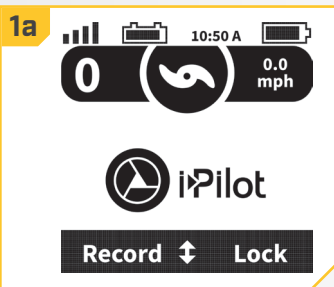
NOTICE: 16 iTrack memory locations may be recorded.





2

- c. The Record menu brings up a listing of iTracks. Use the Menu Up  and Menu Down  buttons to scroll to one of the iTrack locations.
- d. Press the Ok  button to select an iTrack location. Once a location is selected, the current location of the boat becomes the To Start location of the iTrack being recorded. The Control Head will emit a beep when an iTrack location is selected.

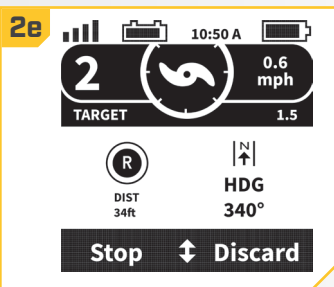
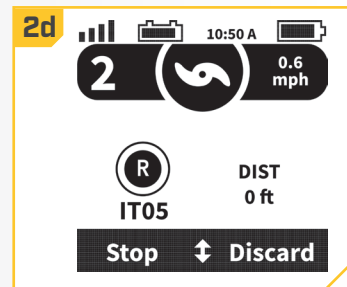
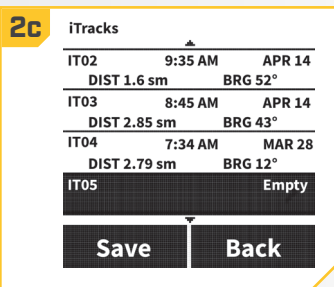



NOTICE: When recording an iTrack location, if an iTrack is already saved to an iTrack memory location, it will automatically write over previously saved data for that memory location. Once a new iTrack is saved into memory, the previous iTrack cannot be recalled. Discarding a recording will keep the previous iTrack in the memory location. Stopping a recording will save the new iTrack location into memory.



- e. Navigate the boat along the desired path or course.
- f. To stop recording an iTrack, use the Menu Up  or Menu Down  buttons until the menu at the bottom of the display screen shows the Stop option.

NOTICE: AutoPilot and/or Cruise Control can be used while recording an iTrack.

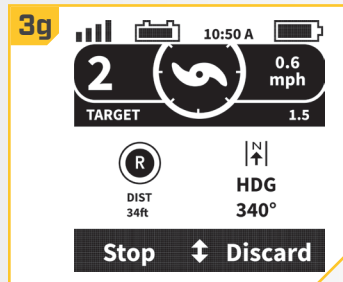

3

- g. Use the Left Softkey  to select Stop.
- h. The recording will end automatically if the two-mile distance limit is reached for the iTrack or if the Spot-Lock  or GO TO  button is pressed. It will also stop if the Right Softkey  is used to select Discard.



› Navigating an iTrack

1

- a. Manually navigate the boat to within a quarter mile of any point on the saved iTrack.
- b. Press the GO TO  button on the remote. The remote default is to first bring up saved Spot-Locks. Press the Right Softkey  to bring up saved iTracks.







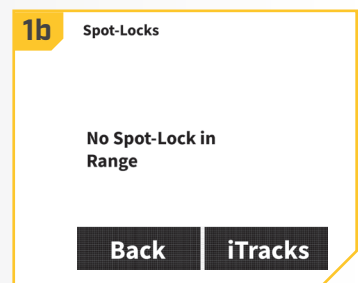
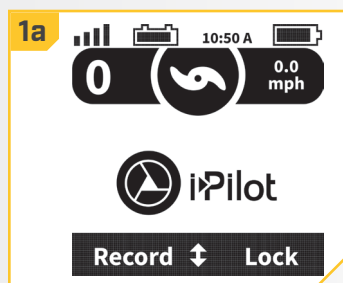

WARNING

Due to safety reasons, i-Pilot will not re-engage a saved iTrack greater than a quarter mile away.



NOTICE: If there are no Spot-Locks or iTracks in range, the remote will state there are none in range.

2

- c. Use the Menu Up  or Menu Down  buttons to select an iTrack to navigate.
- d. Using the Left Softkey  or Right Softkey  select the menu option to either go To Start or To End. The boat will navigate to the closest point recorded in memory on the iTrack and then navigate To Start or To End depending on the selection made until it reaches that point.
- e. The direction that the iTrack is being navigated can be reversed while the iTrack navigation is taking place. Use the Menu Up  or Menu Down  buttons until the menu at the bottom of the display screen shows the Reverse option. Use the Left Softkey  to select Reverse.

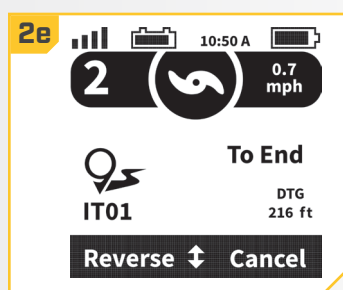
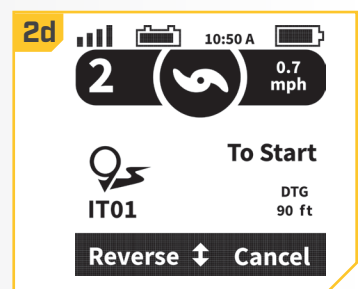
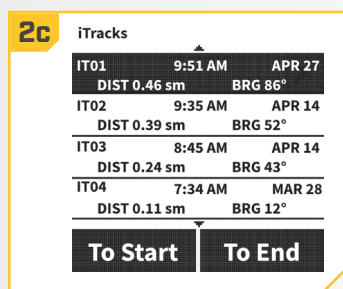

NOTICE: If Auto Prop On is turned "off" the prop must be enabled before the boat will begin navigating an iTrack.







ITRACK ARRIVAL MODES >

iTrack has four Arrival Modes:

1. Off - Once the boat has completed navigating the iTrack, the Prop will turn off. Off is the default Arrival Mode.
2. Spot-Lock - After the boat has completed navigating the iTrack, the system will go into Spot-Lock at the point where the iTrack is completed.
3. AutoPilot - Once the boat has completed navigating the iTrack, it will continue navigating in AutoPilot in the final direction the boat was traveling to navigate the iTrack.
4. Auto Deploy Talon - Available as an option only when the i-Pilot System is paired with a Talon. After the boat has completed navigating the iTrack, the system will deploy the Talon. If i-Pilot is paired with two Talons paired together, the action to Auto Deploy Talon will control both Talons.



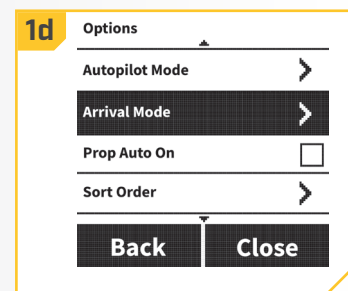
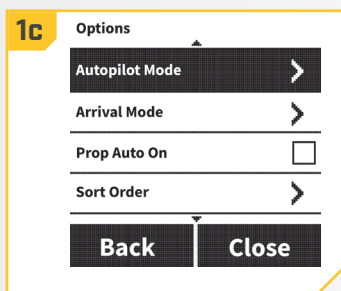
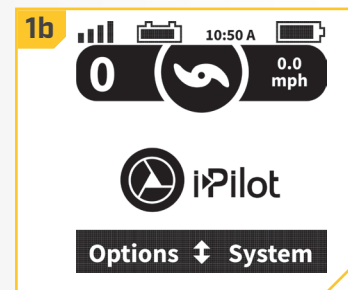
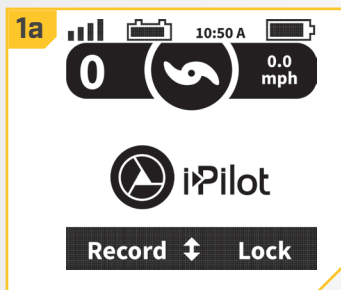

> Change iTrack Arrival Mode

1

- a. Press the Home  button.
- b. Use the Menu Up  and Menu Down  buttons to find the Options menu.
- c. Press the Left Softkey  to select the Options menu.
- d. Use the Menu Up  and Menu Down  buttons to find the Arrival Mode menu. Press the Ok  button to select Arrival Mode.



2

- e. Use the Menu Up  and Menu Down  buttons to find the desired Arrival Mode.
- f. Use the Ok  button to select it. The circle to the right of the selected Arrival Mode will become solid when selected.
- g. Use the Right Softkey  to Close the Arrival Mode Menu or Press the Home  button return to the home screen.

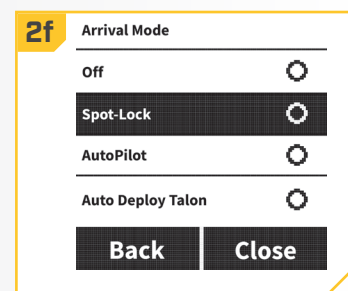
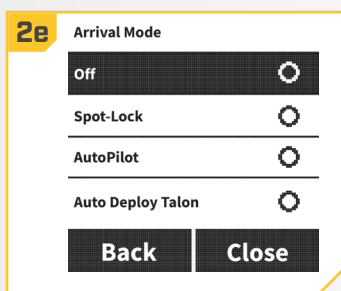

HEADING SENSOR

HEADING SENSOR FEATURES

Become familiar with the features of the Heading Sensor to maximize the capabilities it offers.

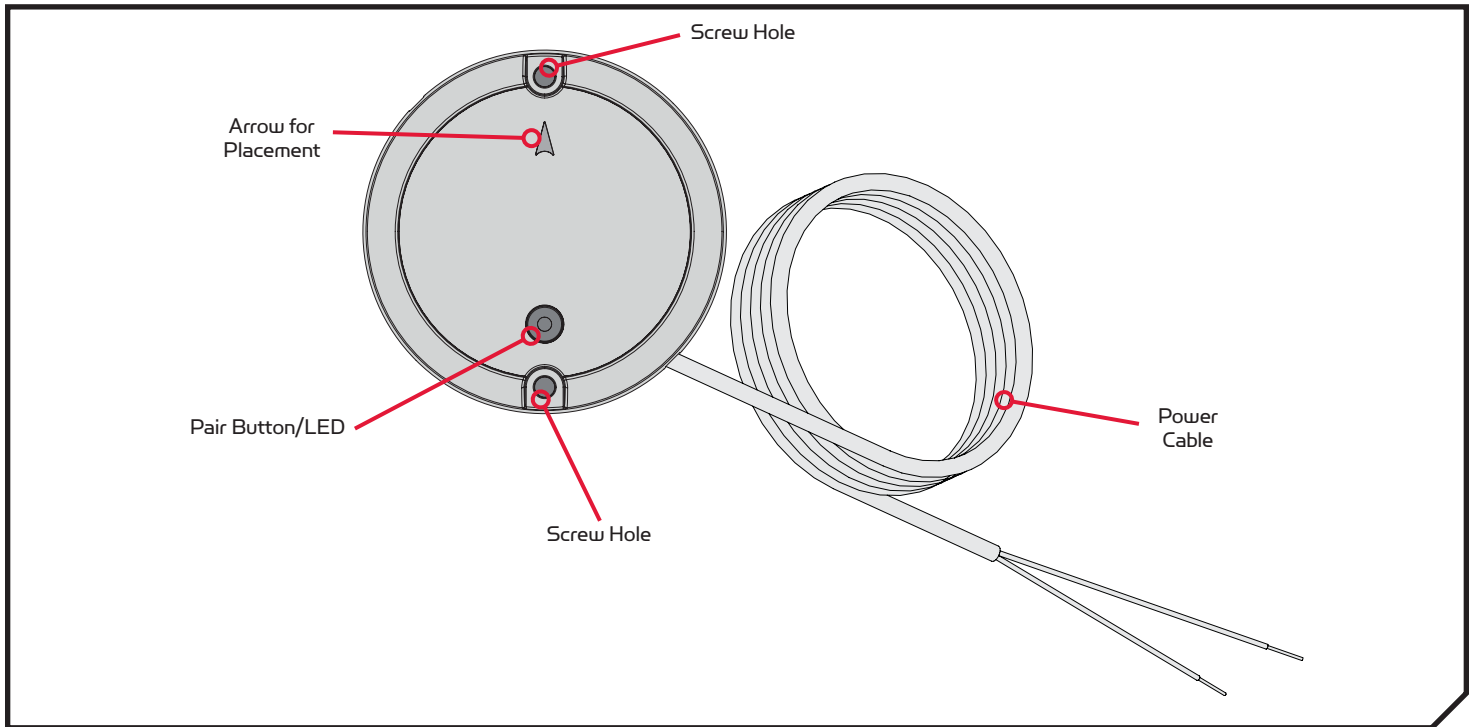

Heading Sensor Functions

The Minn Kota Heading Sensor provides boat heading information to a Bluetooth compatible i-Pilot equipped Minn Kota motor. It contains a compass that senses the boat's heading. The heading is used by the i-Pilot system for navigation features such as Spot-Lock Jog. The Heading Sensor does not contain a GPS receiver and it does not change or control the orientation of the boat. The Minn Kota Heading Sensor can only communicate with other Bluetooth compatible Minn Kota products.

NOTICE: The Heading Sensor does not come standard with all models. It can be purchased as an accessory. To learn more about Minn Kota accessories, please visit www.minnkotamotors.com.

WARNING

The Heading Sensor should not be used as a navigational aid to prevent collision, grounding, boat damage, or personal injury. When the boat is moving, water depth may change too quickly to allow time for you to react. Always operate the boat at very slow speeds if you suspect shallow water or submerged objects.

Do not install the Heading Sensor near ferrous metals or near anything that may create a magnetic field or interference. The Heading Sensor must be installed at least 24" from magnetic or ferrous materials on the boat including the base of the motor. Installation near the motor lead wires must also be avoided due to magnetic fields being created during high current draw situations.

Light Patterns

The Heading Sensor displays modes of operation with an LED located on the Pair Button. There are three distinct patterns that the LED will display to communicate different modes of operation. Become familiar with the modes of operation to be sure that the Heading Sensor is powered up and communicating with i-Pilot.

The three LED patterns displayed by the Heading Sensor are:

- 1. Power On - When the Heading Sensor is first connected to a power source, the LED will turn on for 3 seconds and then turn off.
- 2. Pairing - The Heading Sensor can be paired with i-Pilot. While the Heading Sensor is attempting to pair, the LED will flash on and off twice per second for up to 20 seconds. If the Heading Sensor is successfully paired, normal operation will begin. If the Heading Sensor is not paired, the LED will turn off.
- 3. Normal Operation - During normal operation when the Heading Sensor is connected to a power source and paired to and actively communicating with i-Pilot, the LED on the Heading Sensor will flash on and off once every 3 seconds.

INSTALLATION PARTS LIST

| Item / Assembly | Part # | Description | Qty. |
|-----------------|---------|---|------|
| A | 2996400 | HEADING SENSOR ASSEMBLY | 1 |
| 1 | 2393400 | SCREW-#8-18X1-1/2 PPH TY AB SS *STAINLESS STEEL* | 2 |
| 2 | * | HEADING SENSOR | 1 |

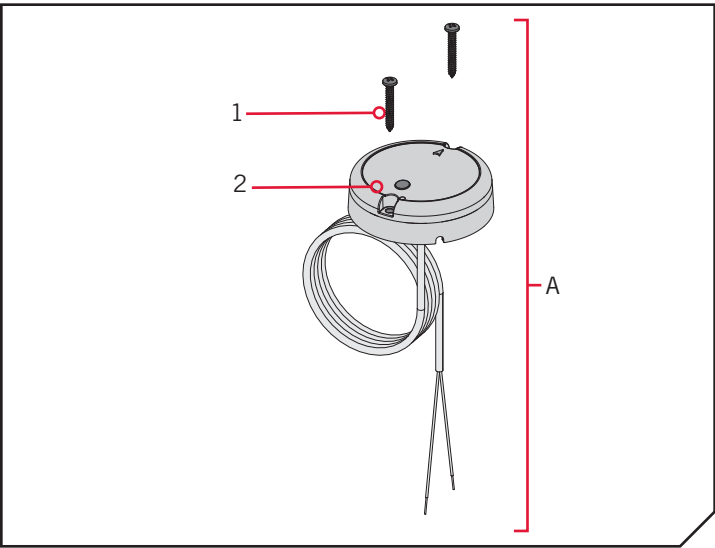

* This part is included in an assembly and cannot be ordered individually.

MOUNTING CONSIDERATIONS

Before mounting your Heading Sensor, give consideration to the following:

- 1. The Heading Sensor contains a compass that detects a magnetic field. Do not install the Heading Sensor near ferrous metals or wires that handle large currents, such as batteries or power cables.
- 2. Mount the Heading Sensor in an area that has a clear line of communication with the head of the motor that is installed with a Bluetooth compatible i-Pilot system for optimum performance.
- 3. Make sure the area under the mounting location is level and is clear to drill holes and installation hardware will not damage existing components below the mounting surface.
- 4. Test that the Power Cable that powers the Heading Sensor is long enough to reach the power source from the intended mounting location. If the cable does not reach the battery or intended power source, select a location closer to the source.
- 5. Mount the Heading Sensor horizontally. It should not be mounted upside down.

⚠ CAUTION

The Heading Sensor can be adversely affected by magnets or large, ferrous metal objects. Do not install the Heading Sensor within 24" of these objects as they will cause interference.

HEADING SENSOR

TOOLS AND RESOURCES REQUIRED

- Drill
- #2 Screwdriver
- Awl or similar marking tool
- 1/4" Drill Bit
- 9/64" Drill Bit
- Marine-grade Silicone

INSTALLATION

MOUNTING OPTIONS

There are two options to install the Heading Sensor. Determine if the Power Cable for the Heading Sensor will pass below the mounting surface.

1. **Access under the Mounting Location** - When installing the Heading Sensor with this option, the Power Cables that come from the Heading Sensor will pass through the mounting surface. Only choose this option when the cables can be accessed after they are passed through the mounting surface. Follow the instructions in the Installation for Access Under the Mounting Location section of this instruction sheet.

2. **No Access under the Mounting Location** - The Power Cables for the Heading Sensor will be routed to the side because there is no room under the mounting location for the cables to pass, or the area below the mounting location is not accessible. Follow the instructions in the Installation for No Access Under the Mounting Location section of this instruction sheet.

It is important to review the mounting considerations and test run the Power Cable before installation.

Installation for Access Under the Mounting Location

1

ITEM(S) NEEDED



- Review the Mounting Considerations and then set the Heading Sensor (Item #2) flat on the selected mounting location and note the placement.
- Lift the Heading Sensor away and mark a point with an awl or similar marking tool beneath the mounting location for the power cable to pass through the surface.
- Using a drill with a 1/4" bit, drill a hole through the mounting location.
- Route the power cable through the drilled hole and feed the cable all the way through until the Heading Sensor sits flat on the mounting location and the cable is completely threaded through the drill hole.

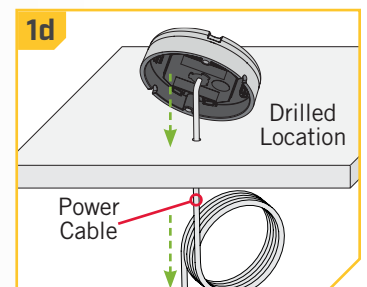
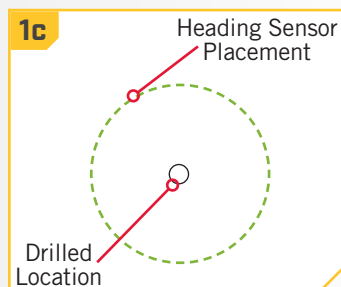
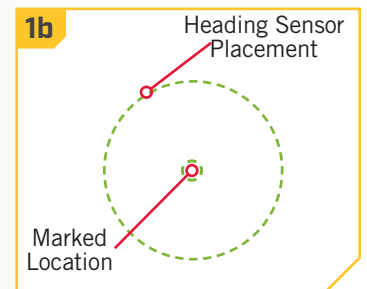
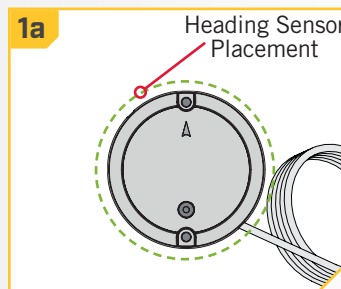

2

- e. Position the sensor so that the arrow on the cover is pointed toward the front of the boat in the direction of travel. **The arrow needs to be parallel with the keel of the boat.**

CAUTION

Failure to align the Heading Sensor correctly will result in incorrect compass readings.

- f. Mark the location of the two screw holes with an awl or similar marking tool.

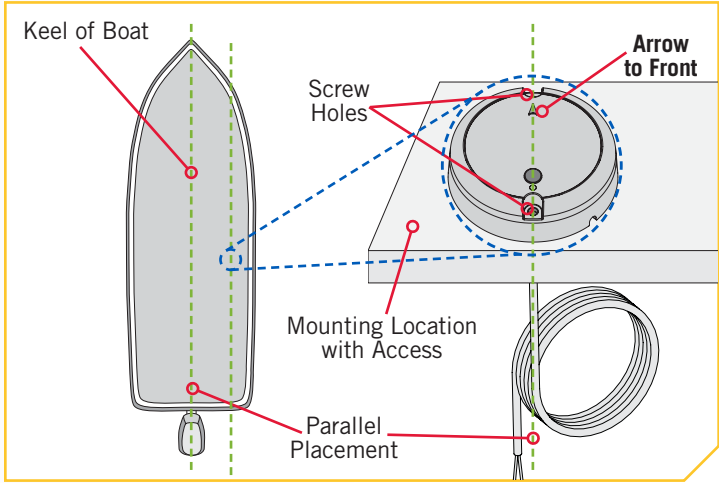

3

- g. Move the Heading Sensor to the side and drill two holes using a 9/64" drill bit on the marked locations.

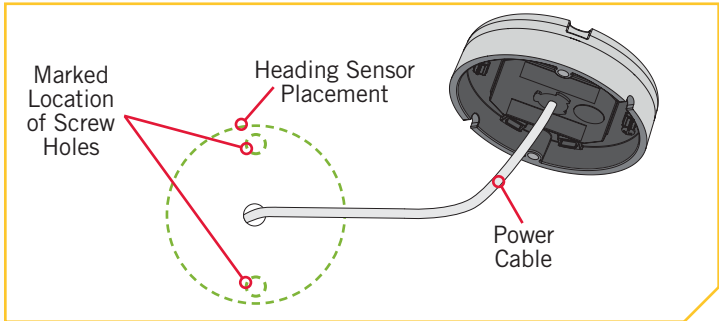

4

- h. Position the Heading Sensor back in place so that the holes drilled in the mounting location line up with the holes in the Heading Sensor and the Power Cable is completely threaded. **Be sure to mount the arrow towards the front of the boat and make the alignment parallel with the keel of the boat.**

CAUTION

Failure to align the Heading Sensor correctly will result in incorrect compass readings.

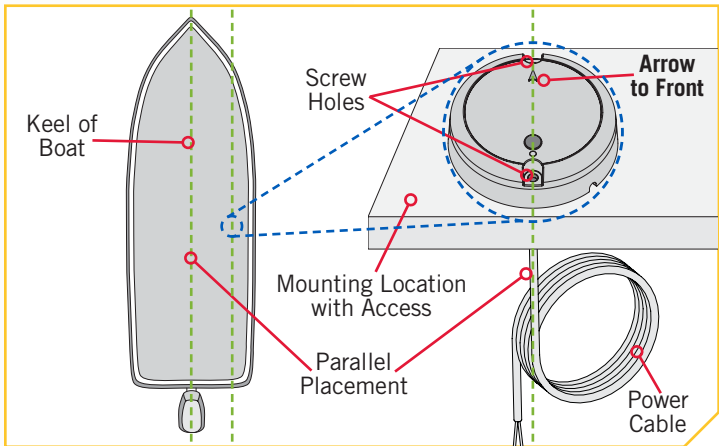

CAUTION

If the mounting surface is thin or made of a lightweight material, the mounting surface may need to be reinforced in order to support the Heading Sensor. Hand tighten the mounting screw to avoid over tightening and to prevent damage to the mounting location and Heading Sensor.

HEADING SENSOR

5

ITEM(S) NEEDED

 #1 x 2

- i. Apply a marine-grade silicone caulk or sealant to both #8 - 18x1-1/2 screws (Item #1) as needed to protect your boat from water damage.
- j. Using a #2 Screwdriver, mount the Heading Sensor to the mounting location using the two screws. Hand tighten only.

NOTICE: If replacement screws must be used, ensure that they are high grade non-magnetic stainless steel.

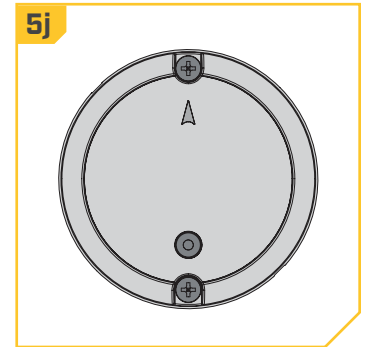
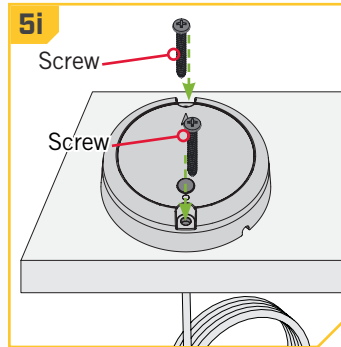

Installation for No Access Under the Mounting Location

1

ITEM(S) NEEDED

 #2 x 1

- a. Review the Mounting Considerations and then set the Heading Sensor (Item #2) flat on the mounting location and note its placement.
- b. Route the power cable through one of the two notches in the base of the Heading Sensor. When the arrow on the Heading Sensor is pointing towards the front of the boat, the cable should exit the Heading Sensor in the direction that is closest to its intended power source.

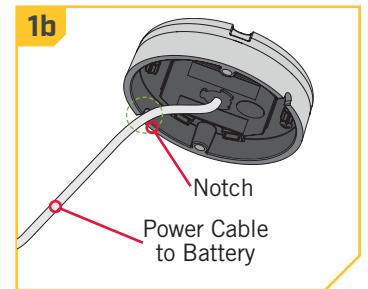
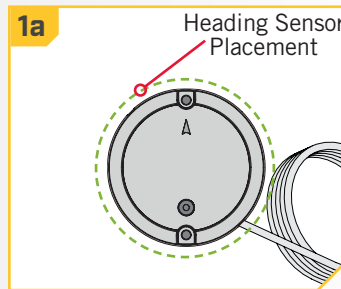

2

- c. Double check the position of the Heading Sensor so that the arrow on the cover is pointed toward the front of the boat in the direction of travel. **The arrow needs to be parallel with the keel of the boat.**

⚠ CAUTION

Failure to align the Heading Sensor correctly will result in incorrect compass readings.

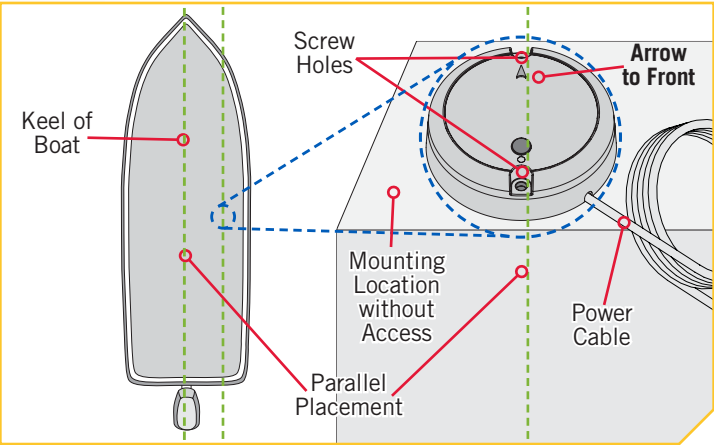

3

- d. Mark the location of the two screw holes with an awl or similar marking tool.
- e. Move the Heading Sensor to the side and drill two holes using a 9/64" drill bit on the marked locations.

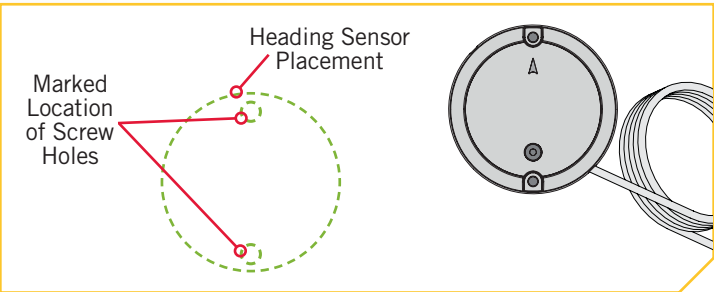

4

ITEM(S) NEEDED

#1 x 2

- f. Position the Heading Sensor back in place so that the holes drilled in the mounting location line up with the holes in the Heading Sensor. **Be sure to mount the arrow towards the front of the boat and make the alignment parallel with the keel of the boat.**
- g. Apply a marine-grade silicone caulk or sealant to both #8 - 18x1-1/2 screws (Item #1) as needed to protect your boat from water damage.

⚠ CAUTION

Failure to align the Heading Sensor correctly will result in incorrect compass readings.

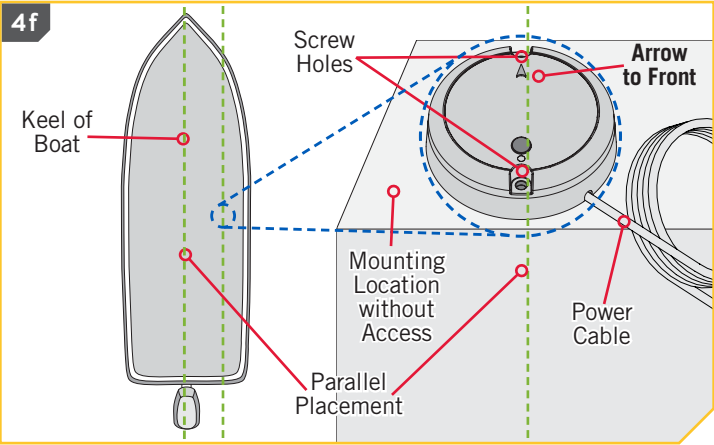

HEADING SENSOR

5

- f. Using a #2 Screwdriver, mount the Heading Sensor to the mounting location using the two screws. Hand tighten only.

CAUTION

If the mounting surface is thin or made of a lightweight material, the mounting surface may need to be reinforced in order to support the Heading Sensor. Hand tighten the mounting screw to avoid over tightening and to prevent damage to the mounting location and Heading Sensor.

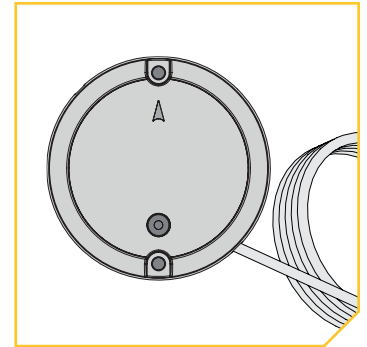
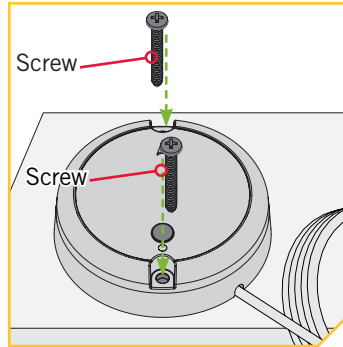

NOTICE: If replacement screws must be used, ensure that they are high grade non-magnetic stainless steel.

Connecting the Heading Sensor to a Power Source

The Heading Sensor is powered by a 12-volt power source. The Heading Sensor must be set up with a one amp fuse, either in-line, or connected to a fuse panel. To connect the Heading Sensor, please follow the directions below.

1. Connect positive (+) red lead to positive (+) power source terminal.
2. Connect negative (-) black lead to negative (-) power source terminal.

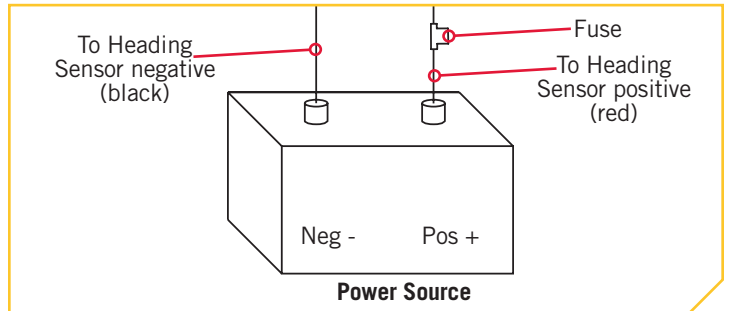

WARNING

Never connect the (+) and the (-) terminals of the same battery together. Take care that no metal object can fall onto the battery and short the terminals. This would immediately lead to a short and extreme fire danger.

WORKING WITH THE HEADING SENSOR >

> Pairing the Heading Sensor

Before the Heading Sensor can be paired, make sure that it has been properly installed and connected to a power source. Review the LED patterns that the Heading Sensor communicates in order to understand what mode it is in and to be able to recognize that it has successfully paired once the process is complete. To pair the Heading Sensor:

- 1
 - a. Connect the Heading Sensor to a power source. Verify that the LED on the Heading Sensor turns on for 3 seconds and then turns off.
 - b. Power on the trolling motor. Please see the trolling motor Owner's Manual for instructions on how to power up the trolling motor.
 - c. Press the Pair button on the Heading Sensor. Verify that the LED indicates it is attempting to pair.

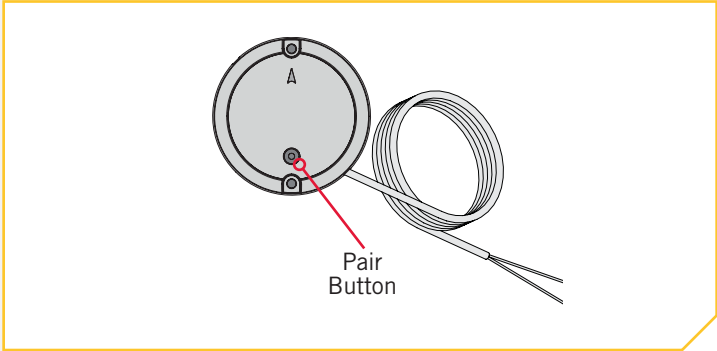

- 2
 - d. As quickly as possible, begin to hold the Pair button on the i-Pilot Control Head.
 - e. The i-Pilot Control Head will emit a beep pattern when the Heading Sensor is successfully paired. Release the Pair button on the Control Head. Watch the Heading Sensor to be sure that once it successfully pairs that it starts emitting the LED pattern for normal operation.
 - f. After the Heading Sensor is paired with i-Pilot or i-Pilot Link, proceed to Sensor Calibration and Sensor Offset.

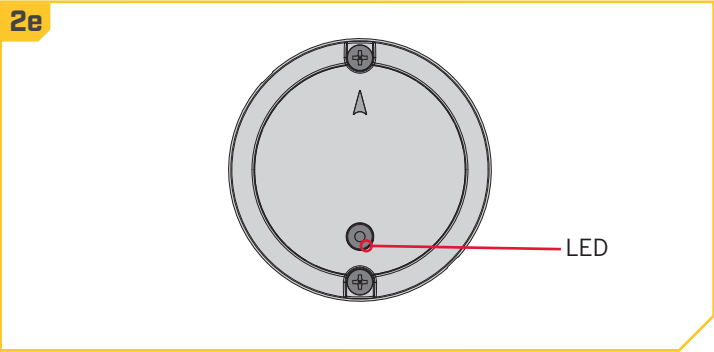
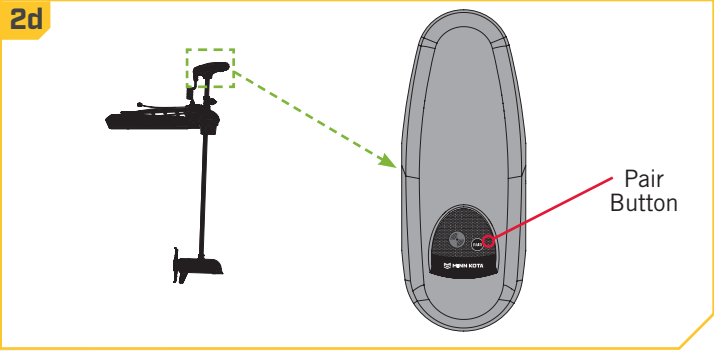

NOTICE: If battery power is lost, the Heading Sensor will not lose its Pairing to the i-Pilot System when it is powered down.

› Heading Sensor Calibration

The Heading Sensor calibration is initiated using either the i-Pilot or i-Pilot Link remote. Refer to the Owner's Manual for your motor if you are unsure of the i-Pilot system that comes with your motor. The process of calibrating the Heading Sensor must occur while your boat is on the water. Heading Sensor Calibration should always be performed after the trolling motor and Heading Sensor have been mounted, but before the Heading Sensor Offset is performed. The Heading Sensor must be connected to power and paired with the Control Head of the trolling motor before beginning this process. The calibration process requires the boat to be driven in two complete circles, so plan accordingly when preparing for this process. To complete this process, read all safety warnings and follow the procedure below.

WARNING

You are responsible for the safe and prudent operation of your vessel. We have designed your Minn Kota product to be an accurate and reliable tool that will enhance boat operation and improve your ability to catch fish. This product does not relieve you from the responsibility for safe operation of your boat. You must avoid hazards to navigation and always maintain a permanent watch so you can respond to situations as they develop. You must always be prepared to regain manual control of your boat. Learn to operate your Minn Kota product in an area free from hazards and obstacles.





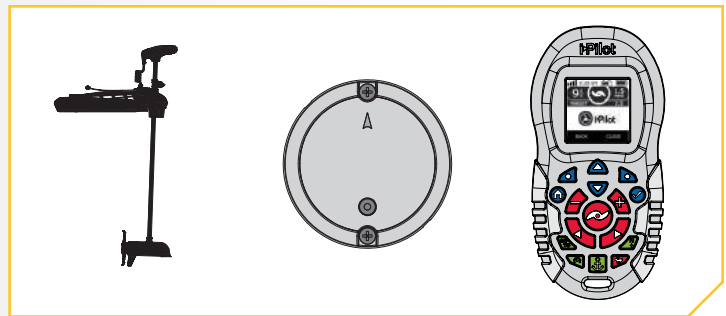

WARNING

Take care that neither you nor other persons approach the turning propeller too closely, neither with body parts nor with objects. The motor is powerful and may endanger or injure you or others. While the motor is running watch out for persons swimming and for floating objects. Persons whose ability to run the motor or whose reactions are impaired by alcohol, drugs, medication, or other substances are not permitted to use this motor.

- 1**
 - a. Review all safety warnings and then navigate your boat to an area of the water that is free from obstructions.
 - b. Power up the trolling motor according to the instructions provided in the Owner's Manual. Make sure the Heading Sensor is also powered up and paired with the trolling motor.
 - c. Turn on the remote for your i-Pilot system.



2

- d. On the i-Pilot remote, use the Menu Up  and Menu Down  buttons to find the System menu at the bottom of the display screen.
- e. Use the Right Softkey  to select the System menu.
- f. Use the Menu Up  and Menu Down  buttons to find the Sensor Cal menu at the bottom of the display screen. Use the Ok  button to select it.
- g. The Sensor Cal screen will display.

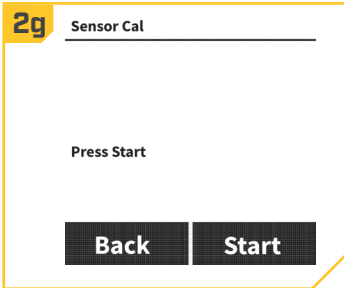
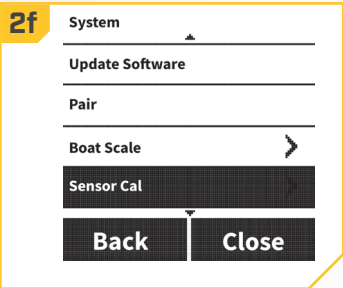
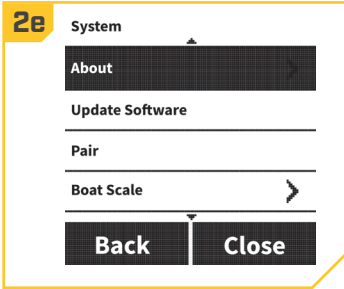
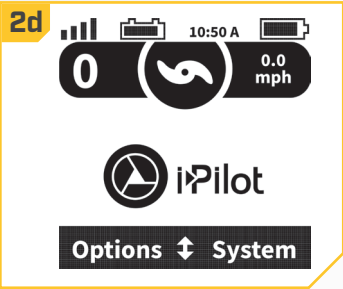

3



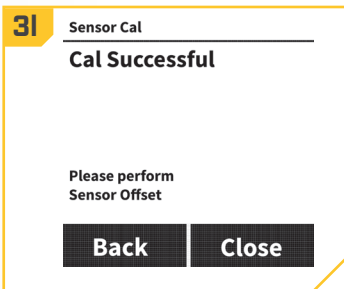
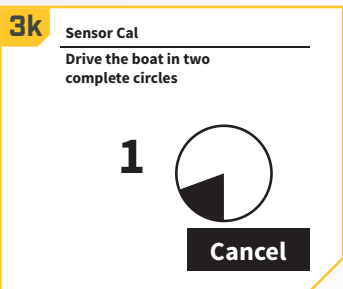
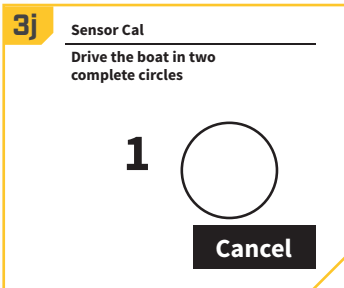
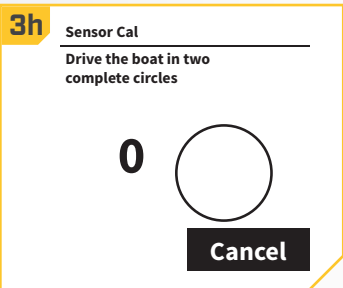



- h. Use the Right Softkey  to select the Start menu.
- i. Review all safety warnings and then follow the prompts on the display screen and drive the boat in two complete circles.
- j. The left side of the Display Screen contains a counter that shows the number of complete turns that the boat has been driven and will increase from 0 to 1 and 2 as the circles are complete.
- k. The Circle on the right side of the display screen will show how complete the boat has progressed through the current circle and will fill in like a pie chart as the boat progresses.
- l. Once the two complete circles have been completed, the display screen will read Cal Successful.



Heading Offset



Once the Heading Sensor is calibrated, the Heading Offset needs to be set. Heading Offset is the difference between the angle of the Keel of the boat and the angle that the Heading Sensor is mounted to the deck of the boat. During installation, the Heading Sensor was installed to be as parallel to the Keel of the boat as possible. If the boat and Heading Sensor are perfectly parallel and pointing in exactly the same direction, the Offset will be a perfect 0° degrees. Knowing that installations are never perfect, the Heading Offset can be set on the i-Pilot remote to compensate for the difference between the two. Heading Offset has the ability to correct the difference in measurement in a range between +30° and -30° degrees.

1

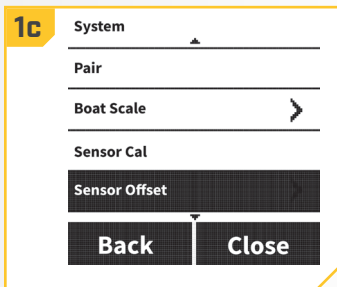
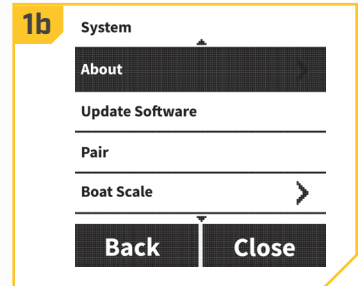
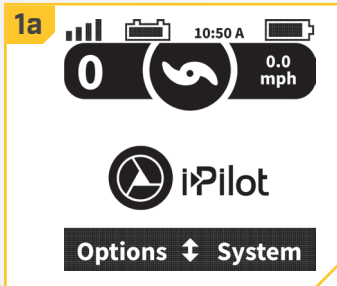
- On the i-Pilot remote, use the Menu Up  and Menu Down  buttons to find the System menu at the bottom of the display screen.
- Use the Right Softkey  to select the System menu.
- Use the Menu Up  and Menu Down  buttons to find the Sensor Offset menu at the bottom of the display screen. Use the Ok  button to select it.
- The Sensor Offset screen will display.



2



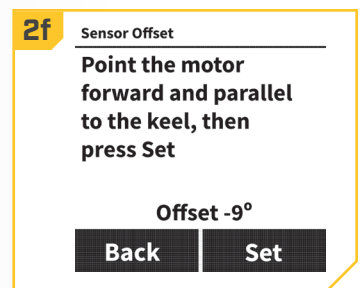
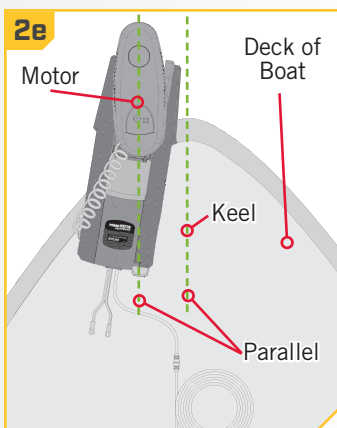



- Turn the motor so that it is parallel with the Keel of the boat.
- Use the Right Softkey  to select the Set menu.
- The Sensor Offset will automatically adjust. Use the Left Softkey  to select Back, or press the Home  button to exit the menu.



MOTOR CONTROLS

› To Toggle the Prop Auto On

1

- Press the Home  button.
- Use the Menu Up  and Menu Down  buttons to find the Options menu at the bottom of the display screen.
- Use the Left Softkey  to select the Options menu.
- In the Options menu, use the Menu Up  and Menu Down  buttons to find the Prop Auto On selection.

NOTICE: When the box next to Prop Auto ON is marked with an X, the prop will turn "on" when navigation features are used. By default the box is not marked.

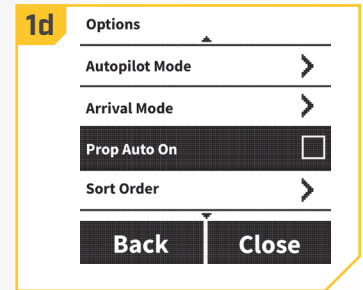
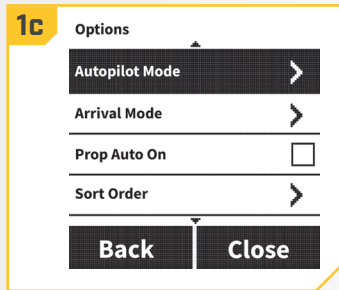
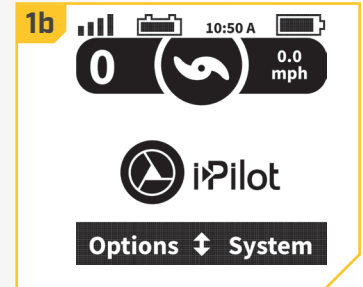
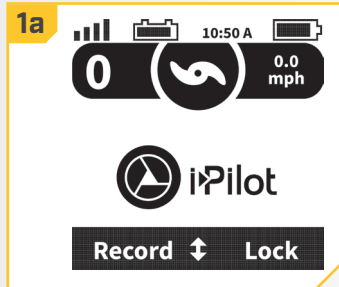



2

- By default, the Prop Auto On is toggled "off".
- To toggle the Prop Auto On, scroll to it in the menu and press the Ok  button to select it.



WARNING

When the Prop Auto On is toggled "on", the prop will turn on when navigation features are used. Navigation features include working with iTracks and AutoPilot. Be sure that the prop is clear from obstructions and hazards when using navigation features.

NOTICE: Prop Auto On is not the same as the Prop ON/OFF  button. Prop Auto On will affect navigational features. The Prop ON/OFF  button refers to the prop status during normal use. If the Prop Auto On feature is engaged, the Prop ON/OFF  button is still functional.

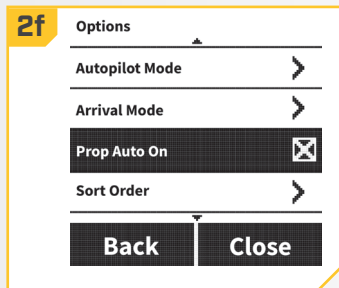

NOTICE: Prop Auto On does not affect the Prop when Cruise Control is being used, or when High Speed Bypass is engaged. If Prop Auto On is not working as expected, check the motor speed. The propeller will turn at the current speed setting when Prop Auto On is engaged. If the Prop Auto on feature turns the prop on, and the propeller is not turning, the speed may be set to zero. Prop Auto On only engages when navigational features, such as navigating to an iTrack or Spot-Lock, are first engaged.







Adjusting Boat Scale

Ideal installation for a trolling motor is to have the proper amount of thrust for the size of the boat the trolling motor is being installed on. If the motor thrust is not properly matched to the boat size, Boat Scale can be used to compensate for the mis-match. The default is zero, assuming that the boat and trolling motor thrust are properly matched. For an installation where the motor thrust is undersized for the boat, increase the Boat Scale. For installation where the motor thrust is oversized for the boat, decrease Boat Scale.



Thrust requirements are determined by the size and weight of your boat. Minn Kota suggests selecting a trolling motor with at least 2 lbs. of thrust for every 100 lbs. of boat weight when the boat is fully loaded with fuel, people, tackle, etc. This guide is established under normal lake fishing conditions and should be used as a general guide to determine how ideally the thrust of your trolling motor is matched to the weight of your boat.

| Boat Weight in Pounds | Suggested MINIMUM Trolling Motor Size in Pounds of Thrust | Voltage | Max Boat Length |
|-----------------------|--|---------|-----------------|
| 1,500 or below | 30 | 12 | 14' |
| 2,000 | 40 - 45 | 12 | 17' - 18' |
| 2,500 | 50 - 55 | 12 | 20' - 21' |
| 3,000 - 3,500 | 70 | 24 | 23' |
| 4,000 | 80 | 24 | 25' |
| 4,500 - 5,000 | 101 - 112 | 36 | 25' |

1

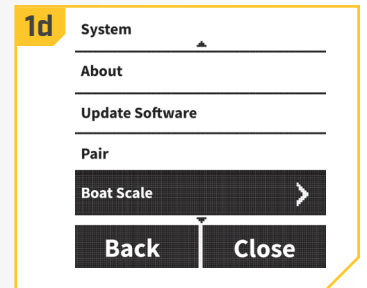
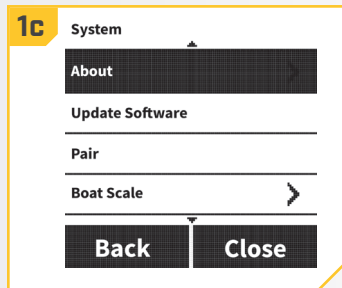
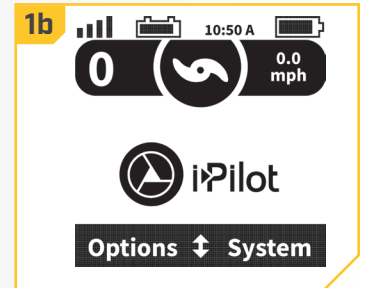
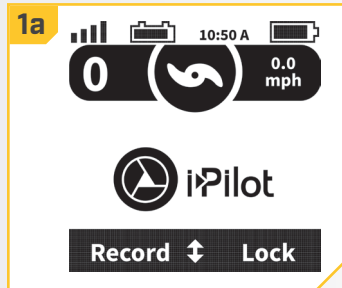

- a. Press the Home  button.
- b. Use the Menu Up  and Menu Down  buttons to find the System menu at the bottom of the display screen.
- c. Use the Right Softkey  to select the System menu.
- d. Use the Menu Up  and Menu Down  buttons to find the Boat Scale menu. Use the Ok  button to select it.

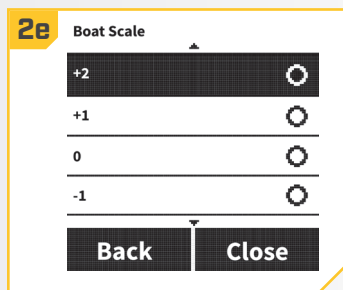

- 2**
- e. Use the Menu Up  and Menu Down  buttons to scroll to +2, +1, 0, -1, or -2.
 - f. Use the Ok  button to select the option highlighted. The circle to the right of the selected Boat Scale will become solid when selected.



› Deploying the Motor ◊

- 1**
- a. Press the Home  button.
 - b. Use the Menu Up  and Menu Down  buttons to find the Deploy menu at the bottom of the display screen.

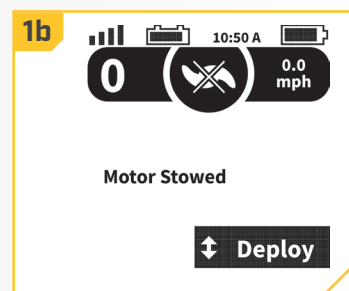
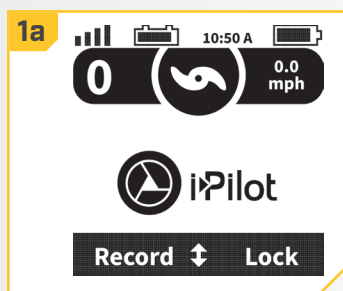

NOTE: The Deploy menu at the bottom of the display screen can only be found when the motor is stowed.



- 2**
- c. Use the Right Softkey  to select the Deploy menu by double pressing it. Once selected the motor will automatically deploy.

WARNING

As soon as the Deploy menu is selected, the motor will automatically deploy. Be sure the motor is clear from obstructions and has a clear path of travel. The Prop is disabled while the motor is stowed and being deployed to prevent accidental contact with the rotating propeller.

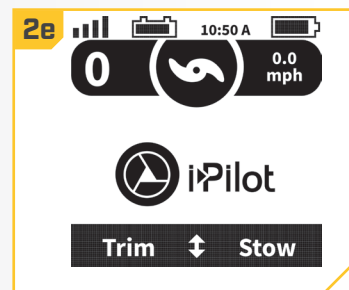
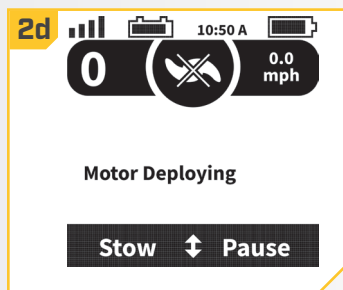

- d. While the Motor is deploying, it is possible to stop the action. Use either the Left Softkey  to select the Stow menu or the Right Softkey  to select the Pause menu.
- e. If the Motor continues, it will complete the deploy process, normal motor operation will follow.



◊ Only available with Ulterra.

› Stowing the Motor ◊

1

- a. Press the Home  button.
- b. Use the Menu Up  and Menu Down  buttons to find the Stow menu at the bottom of the display screen.

NOTICE: The Stow menu at the bottom of the display screen can only be found when the motor is deployed.

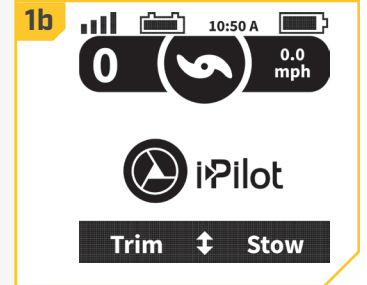
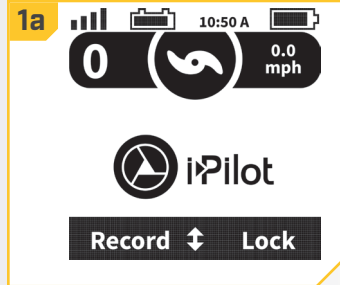



2

- c. Use the Right Softkey  to select the Stow menu. Once selected the motor will automatically stow.

WARNING

As soon as the Stow menu is selected, the motor will automatically stow. Be sure the motor is clear from obstructions and has a clear path of travel. The Prop is disabled while the motor is being stowed to prevent accidental contact with the rotating propeller.



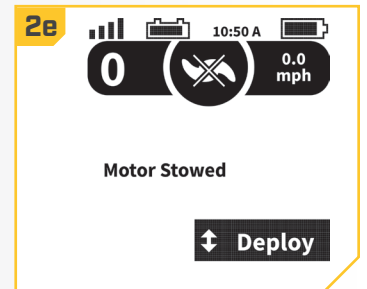
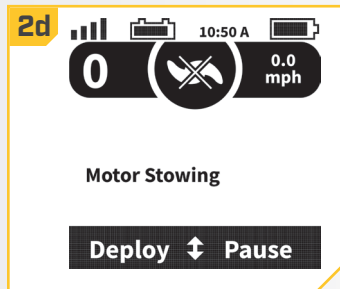



- d. While the Motor is stowing, it is possible to stop the action. Use either the Left Softkey  to select the Deploy menu or the Right Softkey  to select the Pause menu.
- e. If the Motor continues, it will complete the Stow process and the Prop will be disabled.



◊ Only available with Ulterra.

Adjusting Trim ♦

1

- a. Press the Home  button.
- b. Use the Menu Up  and Menu Down  buttons to find the Trim menu at the bottom of the display screen.
- c. Use the Left Softkey  to select the Trim menu.
- d. Use the Menu Up  and Menu Down  buttons to adjust the Boat Trim.
- e. When the motor has reached its highest Trim limit, the Prop will be locked out.
- f. The Prop will stay locked out even when the Trim Motor screen has closed and the motor has not been trimmed down.

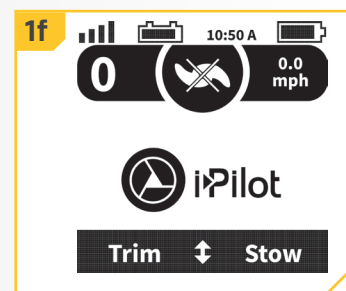
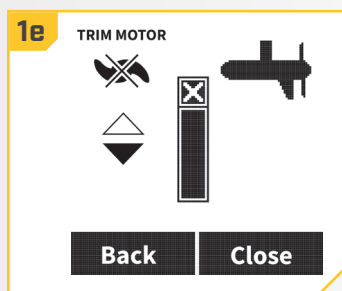
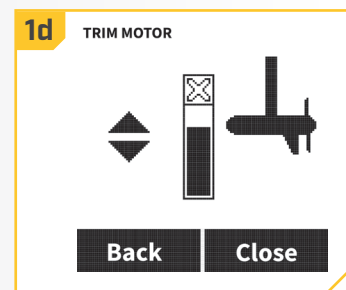
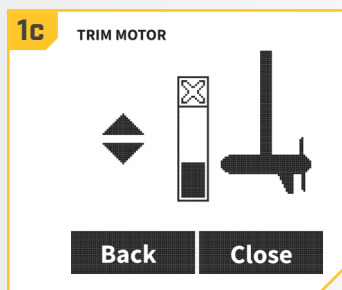
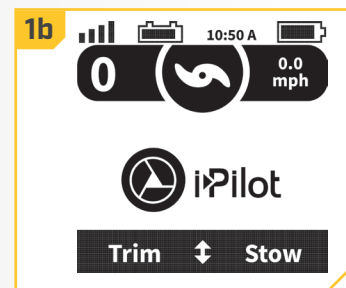
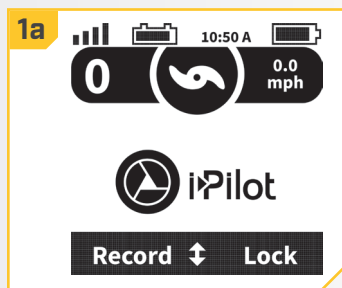





♦ Only available with Ulterra.



TALON CONTROLS

› Deploying the Talon(s)

1

- Press the Home  button.
- Use the Menu Up  and Menu Down  buttons to find the Talon Control menu at the bottom of the display screen.
- Quickly double press the Right Softkey  to select the Down option.

NOTICE: When engaging the Talon to deploy, quickly double press the button twice to deploy. The remote will not recognize the press as a double press if the time between presses is too delayed.

- While the anchor is deploying, the action can be paused on the remote by either pressing the Right Softkey  or Left Softkey  again.
- The paused deployment can be resumed by quickly double pressing the Right Softkey  again.
- Once the deploying anchor gets to its full length of travel or comes in contact with the bottom, it will go through an anchoring sequence determined by the current Mode and then stop.

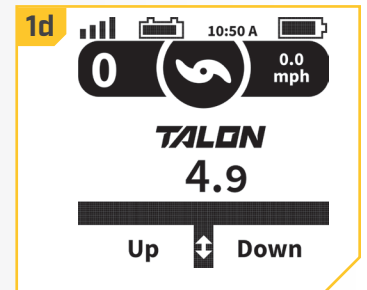
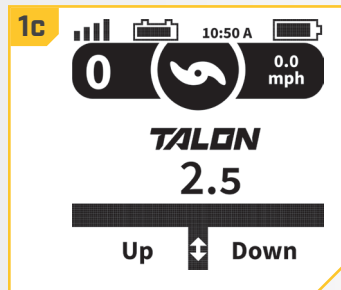
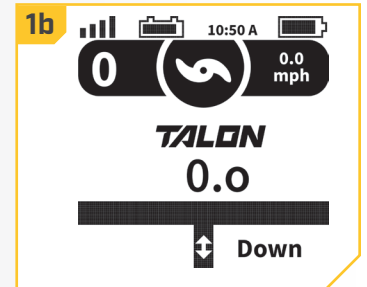
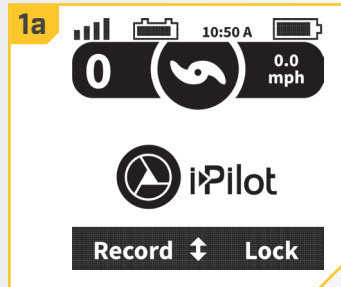

NOTICE: You do not need to press and hold the button to keep the Talon deploying. The Talon will automatically continue to deploy when the button is pressed until it has reached its full deployment length, received input to stop or completes anchoring.

NOTICE: Unless the Talon Control setting on the i-Pilot Remote is set to Right or Left, the remote will control both Talons when deploying. Be mindful of which Talon(s) is selected when deploying them.

WARNING







Take care that neither you nor other persons approach the Talon too closely, while operating, neither with body parts nor with objects. The Talon is powerful and may endanger or injure you or others. While the Talon is operating, watch out for persons swimming and for floating objects. Persons who lack the ability to run the Talon or whose reactions are impaired by alcohol, drugs, medication, or other substances are not permitted to use this product.

CAUTION

The Talon is equipped with a Deployment Notification Alarm. The Alarm is needed to comply with warranty requirements and when properly installed the alarm will only sound when the ignition key is turned on when the Talon is not fully retracted. Boat control may be affected by a deployed Talon. Take note of the Alarm, and always watch to make sure that the Talon is fully retracted while the boat is operating.

Retracting the Talon(s)

Use the buttons on the Indicator Panel to retract the Talon anchor.

- 1
 - a. Press the Home  button.
 - b. Use the Menu Up  and Menu Down  buttons to find the Talon Control menu at the bottom of the display screen.
 - a. To retract the Talon, Left Softkey .
 - b. While the anchor is retracting, the action can be paused on the panel by either pressing the Right Softkey  or Left Softkey  again.
 - c. The paused retraction can be resumed by pressing the Left Softkey  again. Once the retracting anchor on the Talon gets to its fully retracted state, it will stop.

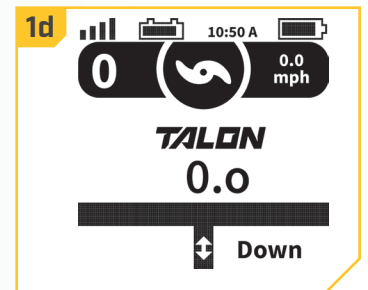
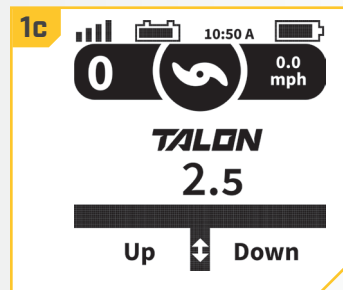
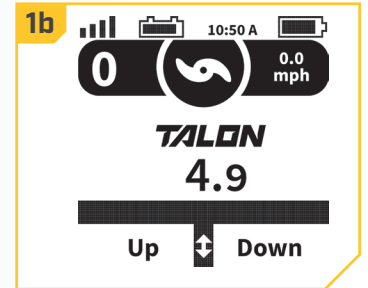
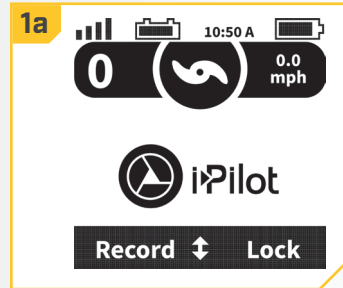

CAUTION





Be sure that the Talon is clear of obstructions and persons while retracting. The spaces between the 3 stages of the Talons can create a pinch point. Do not come in contact with the Talon while it is retracting to avoid the pinch point.

NOTICE: You do not need to press and hold the button to keep the anchor retracting. The Talon will automatically continue to retract when the button is pressed until the Talon is either fully retracted or receives input to stop.

NOTICE: Unless the Talon Control setting on the i-Pilot Remote is set to Right or Left, the remote will control both Talons when retracting. Be mindful of which Talon(s) is selected when retracting them.

Toggle the Talon Anchor Mode

Toggle the Anchor Mode on the i-Pilot Remote when the water or anchoring conditions change to fit your anchoring needs.

- 1
 - a. Press the Home  button.
 - b. Use the Menu Up  and Menu Down  buttons to find the Anchor Mode option at the bottom of the display screen.
 - c. Use the Right Softkey  to toggle between, Standard (Std.), Rough, and Soft. The current Anchor Mode will be visible on the display screen.



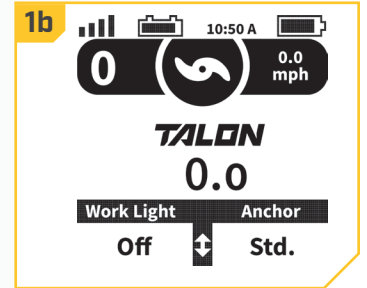
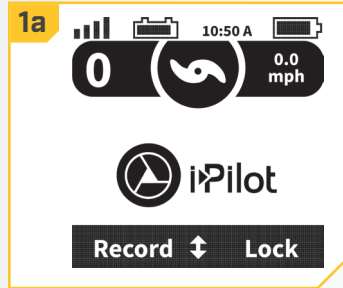

NOTICE: When the i-Pilot System is paired with two Talons, toggling the Anchor Mode on the i-Pilot Remote for one Talon will toggle the Anchor Mode for both Talons.



NOTICE: Read the "Using the Talon" section of the Talon Owner's Manual to learn more about Modes.

Toggle the Work Light Intensity

The Work Light on the Talon has a high - medium - low intensity setting of white LEDs and blue LEDs. When the Work Light is turned on, the LEDs will be either white or blue, and then an intensity setting can be selected.

- 1
 - a. Press the Home  button.
 - b. Use the Menu Up  and Menu Down  buttons to find the Work Light option at the bottom of the display screen.
 - c. Use the Left Softkey  to toggle between, Off, Low, Medium and High. The current Work Light Intensity will be visible on the display screen.



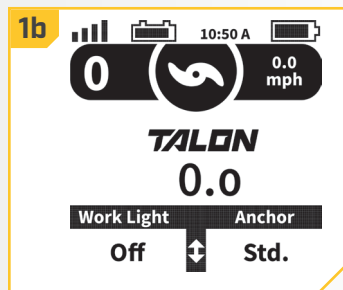
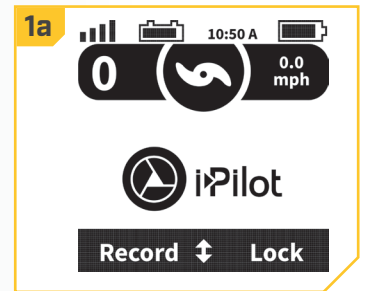
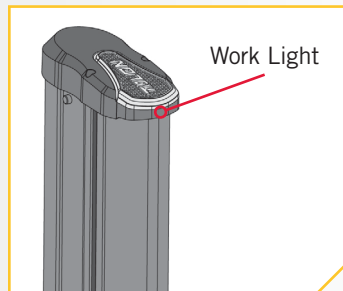



NOTICE: When the i-Pilot System is paired with two Talons, toggling the Work Light Intensity on one Talon will toggle the Work Light Intensity on both.



› Toggle the Work Light Intensity from the Options Menu

It is also possible to toggle the Work Light Brightness from the Options Menu, using the following instructions:

1

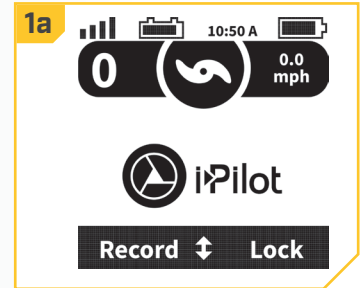
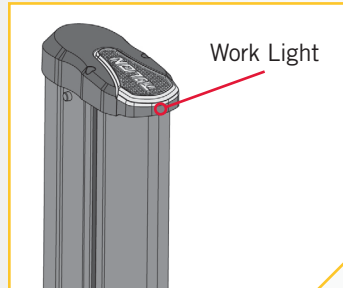

- a. Press the Home  button.
- b. Use the Menu Up  and Menu Down  buttons to find the Options Menu at the bottom of the display screen. Use the Left Softkey  to select it.
- c. In the Options Menu, use the Menu Up  and Menu Down  buttons to scroll to the Worklight Brightness Menu. Use the Ok  button to select it.

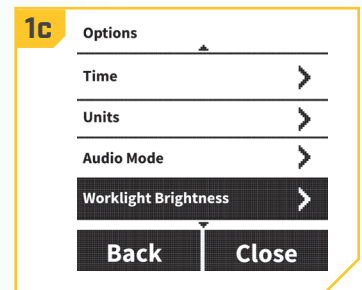
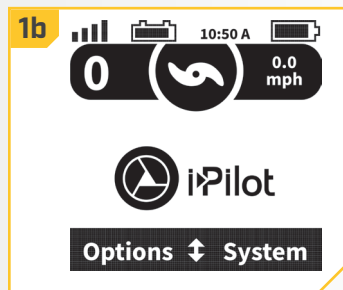

NOTICE: When the i-Pilot System is paired with two Talons, toggling the Work Light Intensity on one Talon will toggle the Work Light Intensity on both.



2



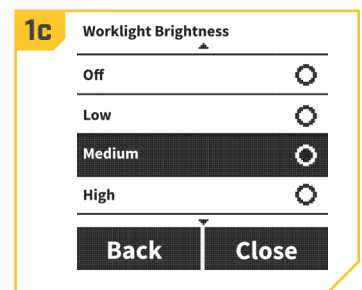
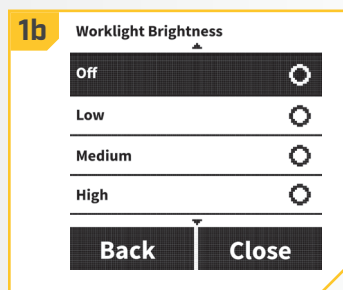



- e. Use the Menu Up  and Menu Down  buttons to scroll to Off, Low, Medium, or High.
- f. Use the Ok  button to select the option highlighted. The circle to the right of the selected Worklight Brightness will become solid when selected.



› Toggle the Work Light Color

When the Work Light is turned on, the LEDs will be either white or blue. The color of the Work Light can be changed from the Options Menu.



1

- a. Press the Home  button.
- b. Use the Menu Up  and Menu Down  buttons to find the Options Menu at the bottom of the display screen. Use the Left Softkey  to select it.
- c. In the Options Menu, use the Menu Up  and Menu Down  buttons to scroll to the Worklight Color Menu. Use the Ok  button to select it.

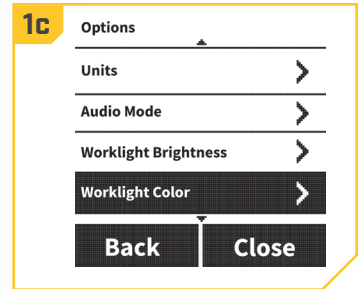
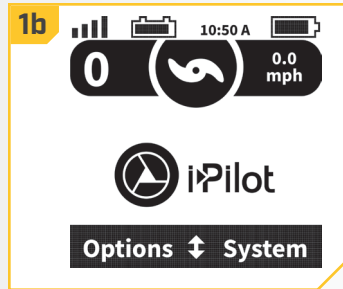
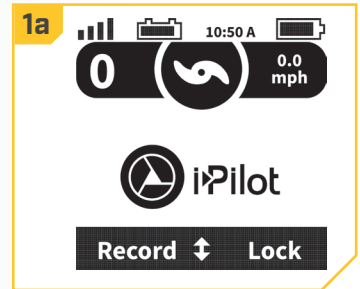
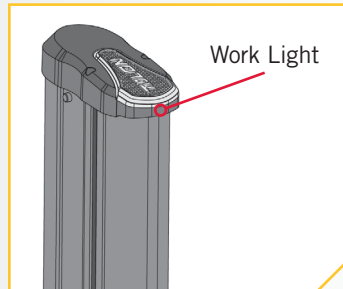
NOTICE: When the i-Pilot System is paired with two Talons, toggling the Work Light Color on one Talon will toggle the Work Light Color on both.



2



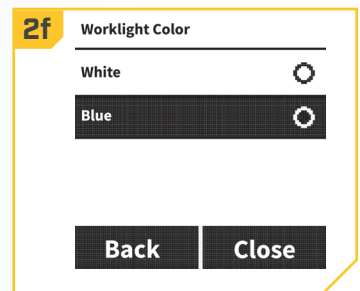
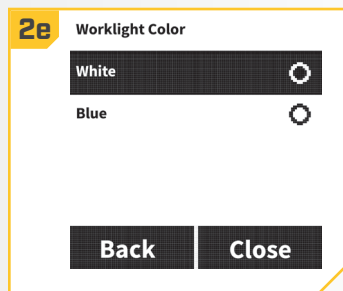



- e. Use the Menu Up  and Menu Down  buttons to scroll to White or Blue.
- f. Use the Ok  button to select the option highlighted. The circle to the right of the selected Worklight Brightness will become solid when selected.



› Toggle the Auto-Retract Message

The i-Pilot Remote will display a message when the Auto-Retract message feature is engaged and the boat is traveling above 5 mph when the Talon is at any percentage of deployment. The remote will not display a message about the Talon if it is deployed and the Auto-Retract is deselected, even if the boat exceeds 5 mph.

1

- a. Press the Home  button.
- b. Use the Menu Up  and Menu Down  buttons to find the Options menu at the bottom of the display screen.
- c. Use the Left Softkey  to select the Options menu.
- d. In the Options menu, use the Menu Up  and Menu Down  buttons to find the Auto-Retract selection.

NOTICE: When the box next to Auto-Retract is marked with an X, the Auto-Retract message is engaged. By default the box is not marked.

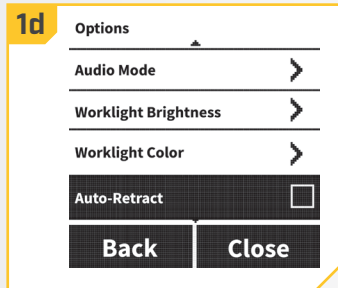
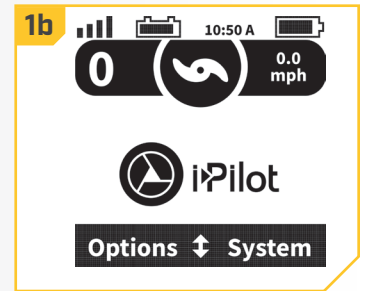
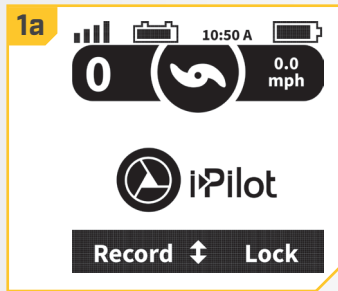

2





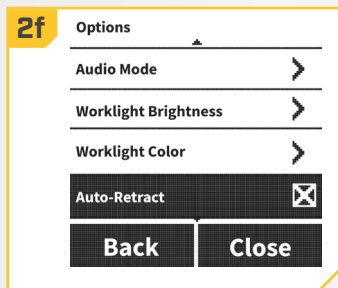

- e. By default, the Auto-Retract is toggled "off".
- f. To toggle the Auto-Retract, scroll to it in the menu and press the Ok  button to select it.

NOTICE: When the i-Pilot System is paired with two Talons, engaging or disengaging the Auto-Retract message on one Talon will engage or disengage the Auto-Retract message on both.







Toggle the Active Talon

When the i-Pilot System is paired to two Talons paired together, it is possible to control either the left or right Talon individually, or together. This is done from the Active Talon Menu selection in the Options Menu.

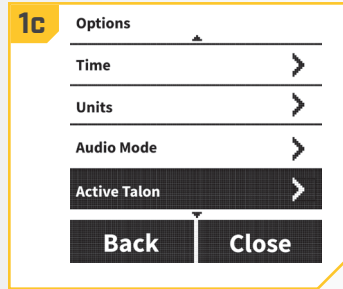
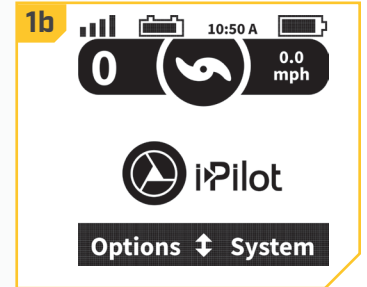
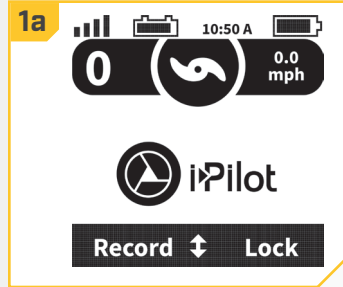
- 1 a. Press the Home  button.
- b. Use the Menu Up  and Menu Down  buttons to find the Options Menu at the bottom of the display screen. Use the Left Softkey  to select it.
- c. In the Options Menu, use the Menu Up  and Menu Down  buttons to scroll to the Active Talon selection. Use the Ok  button to select it.

NOTICE: Changing the ability to stow and deploy the Talon is the only feature that is changed with the Active Talon Menu selection. All other features that are selected for one Talon will apply to both in instances where the i-Pilot System is paired to two Talons paired together.





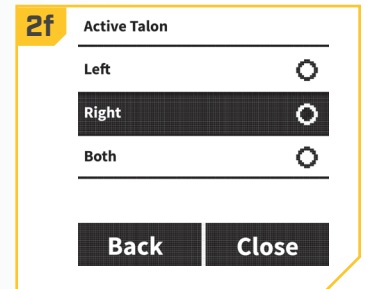
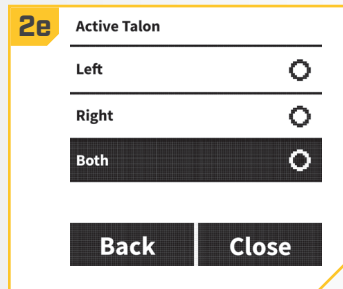



- 2 e. Use the Menu Up  and Menu Down  buttons to scroll to Left, Right, or both.
- f. Use the Ok  button to select the option highlighted. The circle to the right of the selected Active Talon will become solid when selected.



REMOTE CONTROLS





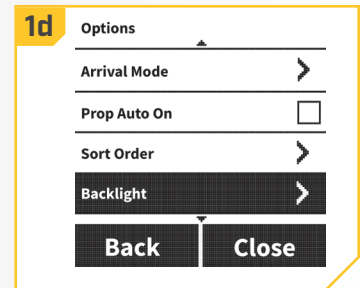
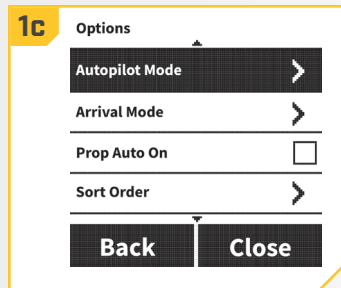
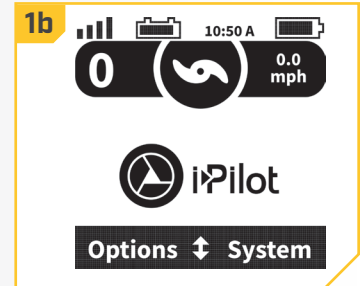
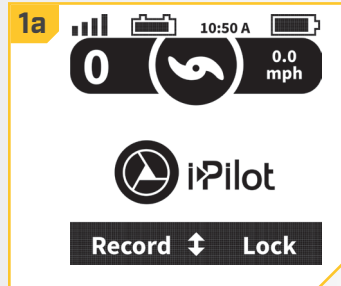

› To Adjust the Backlight Brightness

1

- Press the Home  button.
- Use the Menu Up  and Menu Down  buttons to find the Options menu at the bottom of the display screen.
- Use the Left Softkey  to select the Options menu.
- In the Options menu, use the Menu Up  and Menu Down  buttons to find the Backlight selection. Press the Ok  button to select it.



2



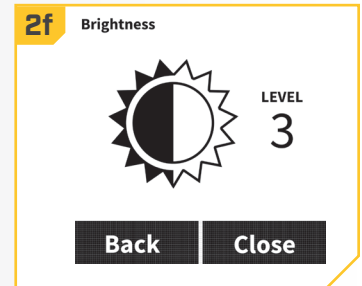
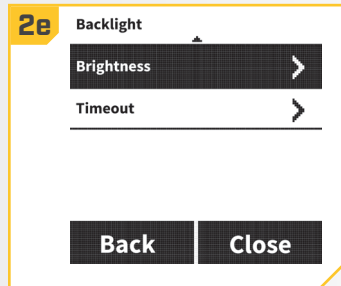



- In the Backlight menu, use the Menu Up  and Menu Down  buttons to find the Brightness selection. Press the Ok  button to select it.
- Use the Menu Up  and Menu Down  buttons to adjust the screen to the desired brightness.
- Once the desired brightness is found, press the Right Softkey  to Close the menu or the Home  button to exit the menu.



NOTICE: Remote battery life is subject to frequency of use and is especially impacted by how often and bright the LCD backlight is used.







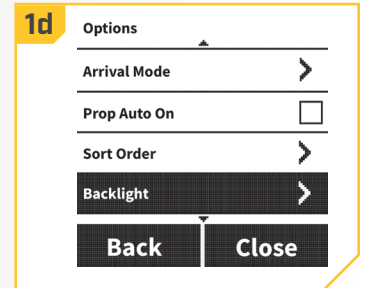
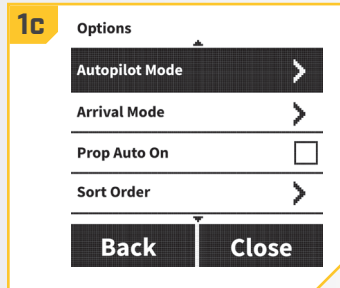
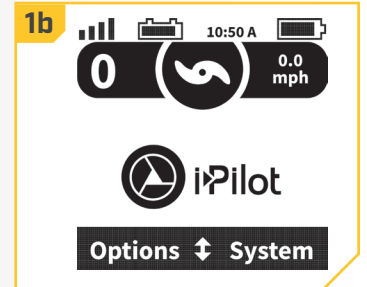
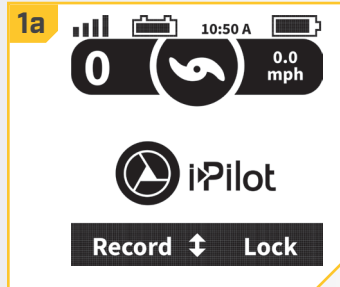

▶ To Adjust the Backlight Timeout

1

- a. Press the Home  button.
- b. Use the Menu Up  and Menu Down  buttons to find the Options menu at the bottom of the display screen.
- c. Use the Left Softkey  to select the Options menu.
- d. In the Options menu, use the Menu Up  and Menu Down  buttons to find the Backlight selection. Press the Ok  button to select it.







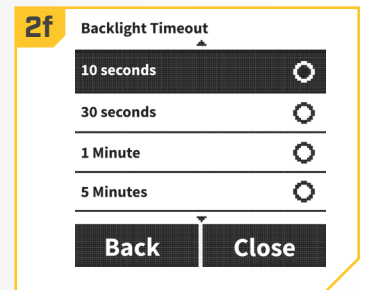
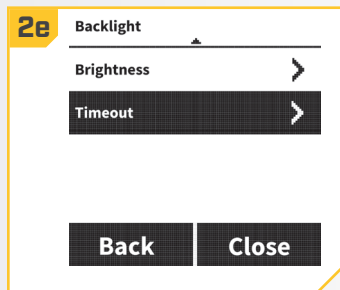

2

- e. In the Backlight menu, use the Menu Up  and Menu Down  buttons to find the Timeout selection. Press the Ok  button to select it.
- f. Use the Menu Up  and Menu Down  buttons to find the desired Backlight Timeout. Use the Ok  button to select it. The circle to the right of the selected Backlight Timeout will become solid when selected.
- g. Once the desired Backlight Timeout is found, press the Right Softkey  to Close the menu or the Home  button to exit the menu.



Restore Defaults

1

- a. Press the Home  button.
- b. Use the Menu Up  and Menu Down  buttons to find the System menu at the bottom of the display screen.
- c. Use the Right Softkey  to select the System menu.
- d. Use the Menu Up  and Menu Down  buttons to find the Restore Defaults option. Use the Ok  button to select it.

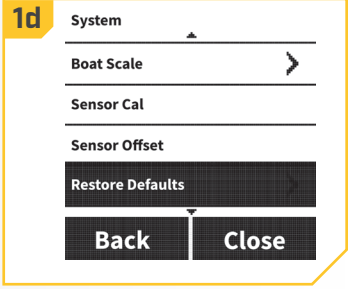
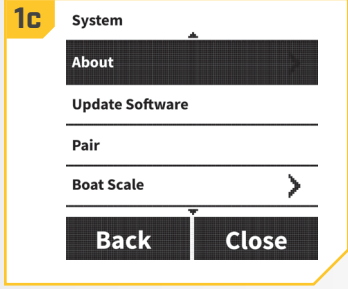
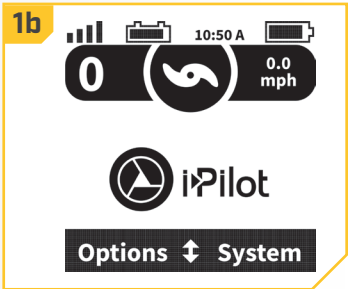
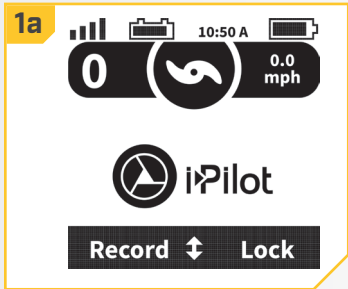

CAUTION

This will restore the i-Pilot's factory settings!

2

- e. Use the Left Softkey  to select the Restore option.

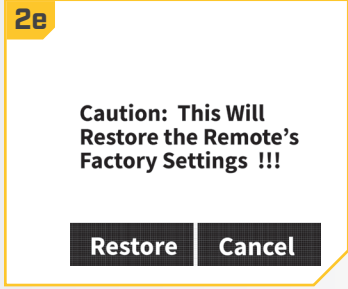

CAUTION

This will restore the i-Pilot's factory settings!



Selecting Remote Language





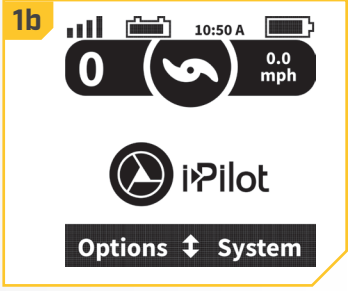
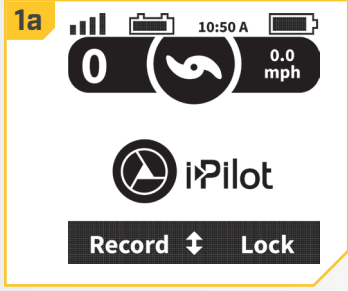

1

- a. Press the Home  button.
- b. Use the Menu Up  and Menu Down  buttons to find the Options menu at the bottom of the display screen.



REMOTE CONTROLS





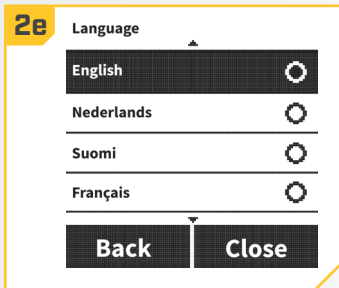
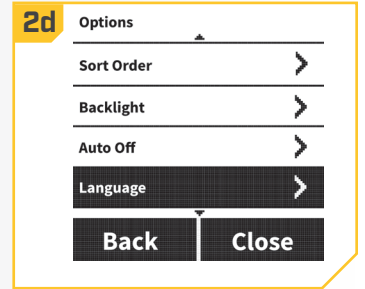
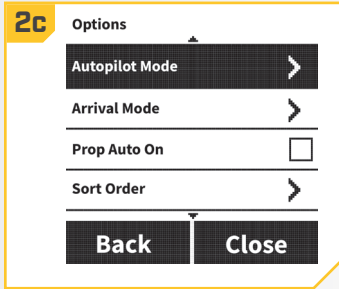



2

- c. Use the Left Softkey  to select the Options menu.
- d. Use the Menu Up  and Menu Down  buttons to find the Language menu. Use the Ok  button to select it.
- e. Use the Menu Up  and Menu Down  buttons to find the desired language. Use the Ok  button to select it. The circle to the right of the selected Language will become solid when selected.



> Change the Distance Units

1

- a. Press the Home  button.
- b. Use the Menu Up  and Menu Down  buttons to find the Options menu at the bottom of the display screen.
- c. Use the Left Softkey  or Right Softkey  to select the Options menu.
- d. Use the Menu Up  and Menu Down  buttons to find the Units menu. Use the Ok  button to select it.

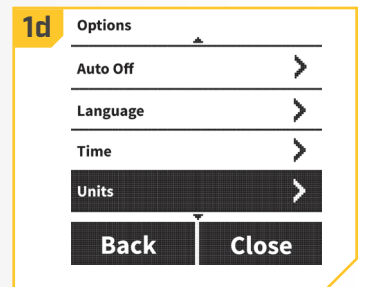
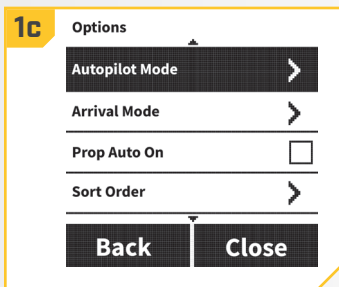
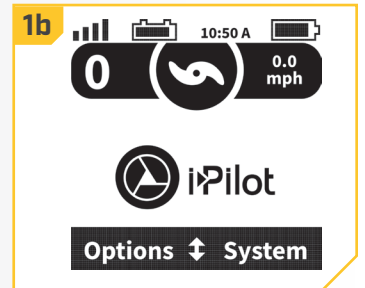
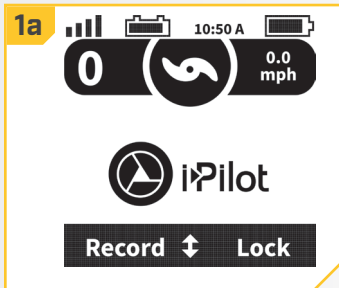

2

- e. Use the Menu Up ▲ and Menu Down ▼ buttons to find the Distance menu. Use the Ok ⏏ button to select it.
- f. Use the Menu Up ▲ and Menu Down ▼ buttons to scroll to the desired unit of measurement. Use the Ok ⏏ button to select it. The circle to the right of the selected Distance Unit will become solid when selected.

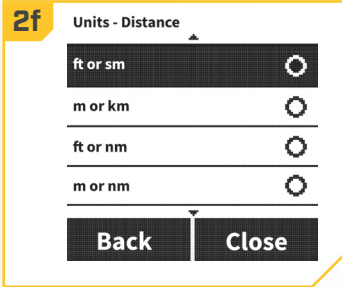
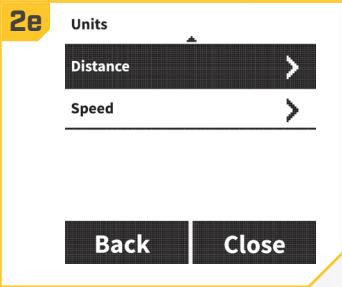

Change the Speed Units

1

- a. Press the Home ⏠ button.
- b. Use the Menu Up ▲ and Menu Down ▼ buttons to find the Options menu at the bottom of the display screen.
- c. Use the Left Softkey ⏏ to select the Options menu.
- d. Use the Menu Up ▲ and Menu Down ▼ buttons to find the Units menu. Use the Ok ⏏ button to select it.

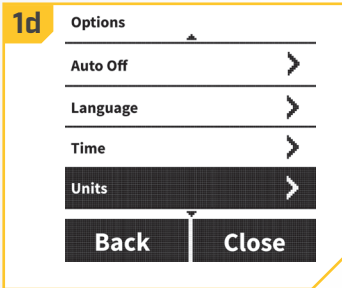
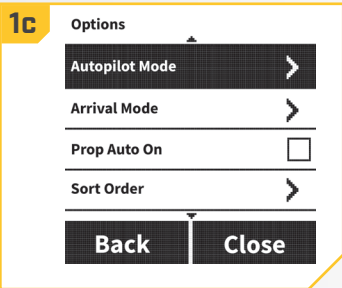
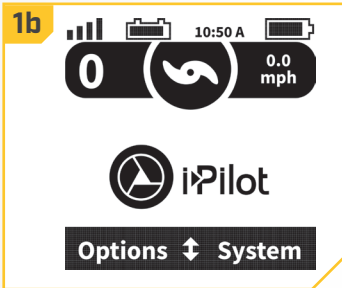
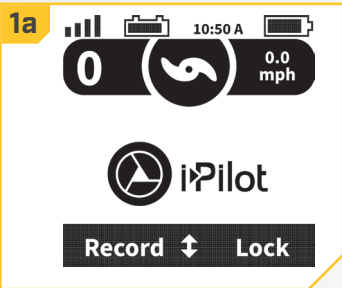

2

- e. Use the Menu Up ▲ and Menu Down ▼ buttons to find the Speed menu. Use the Ok ⏏ button to select it.
- f. Use the Menu Up ▲ and Menu Down ▼ buttons to scroll to the desired unit of measurement. Use the Ok ⏏ button to select it. The circle to the right of the selected Speed Units will become solid when selected.

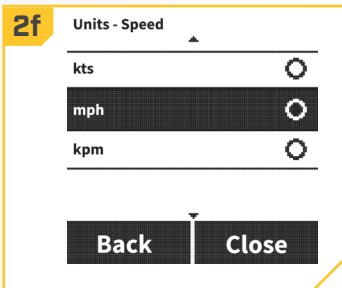
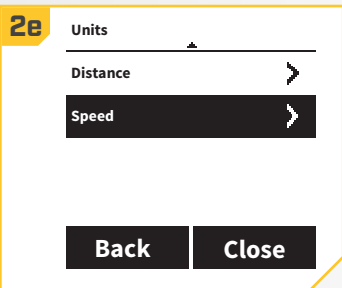

Change the Time Format

1

- Press the Home button.
- Use the Menu Up and Menu Down buttons to find the Options menu at the bottom of the display screen.

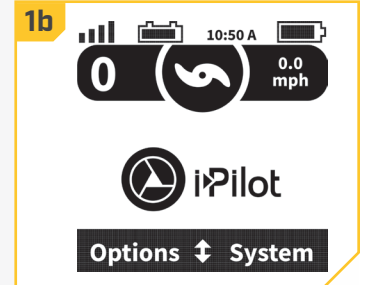
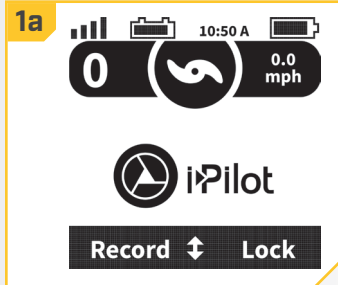

2

- Use the Left Softkey to select the Options menu.
- Use the Menu Up and Menu Down buttons to find the Time menu. Use the Ok button to select it.
- Use the Menu Up and Menu Down buttons to find the desired time display option. Use the Ok button to select it. The circle to the right of the selected time format will become solid when selected.

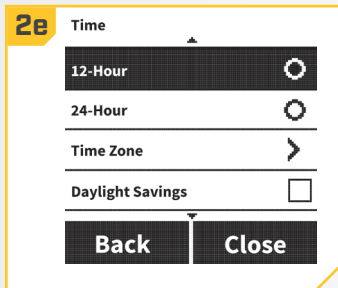
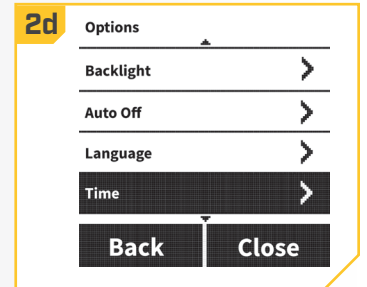
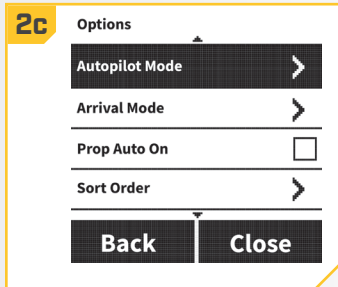







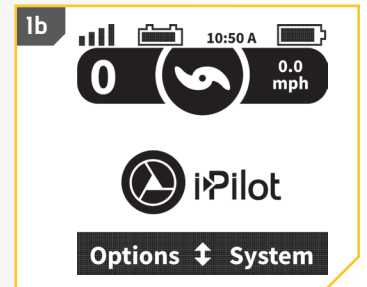
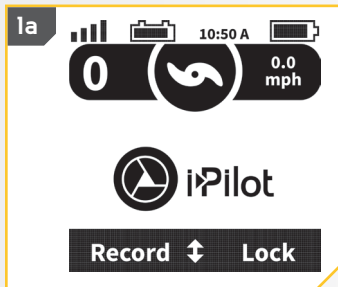



Change the Time Zone

1

- Press the Home button.
- Use the Menu Up and Menu Down buttons to find the Options menu at the bottom of the display screen.







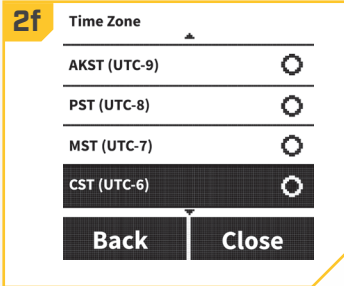
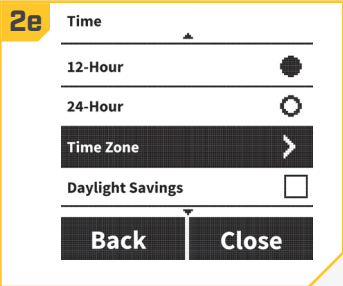
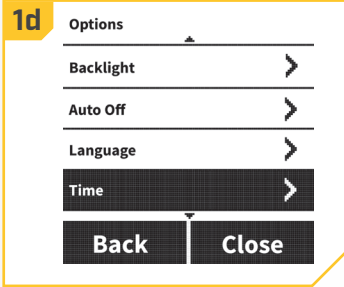
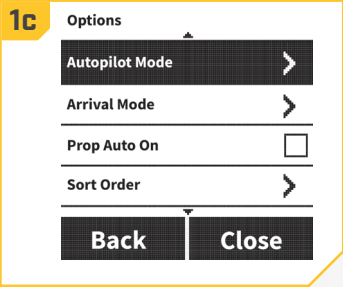

2

- c. Use the Left Softkey  to select the Options menu.
- d. Use the Menu Up  and Menu Down  buttons to find the Time menu. Use the Ok  button to select it.
- e. Use the Menu Up  and Menu Down  buttons to find the Time Zone menu. Use the Ok  button to select it.
- f. Use the Menu Up  and Menu Down  buttons to find the desired Time Zone. Use the Ok  button to select it. The circle to the right of the selected Time Zone will become solid when selected.





Toggle Daylight Savings

1

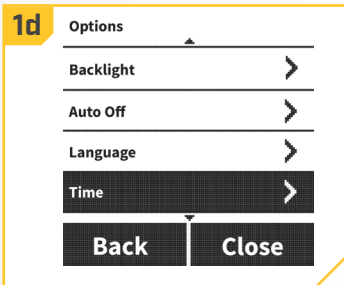
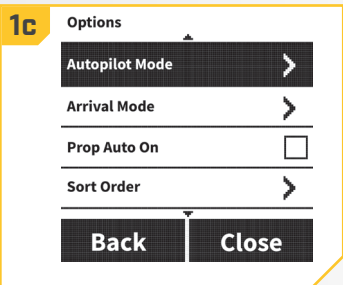
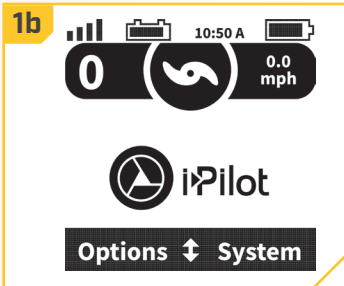
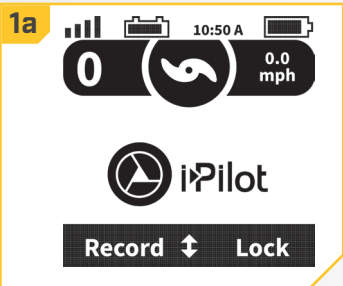
- a. Press the Home  button.
- b. Use the Menu Up  and Menu Down  buttons to find the Options menu at the bottom of the display screen.
- c. Use the Left Softkey  to select the Options menu.
- d. Use the Menu Up  and Menu Down  buttons to find the Time menu. Use the Ok  button to select it.



2





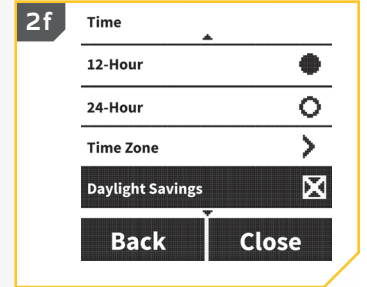
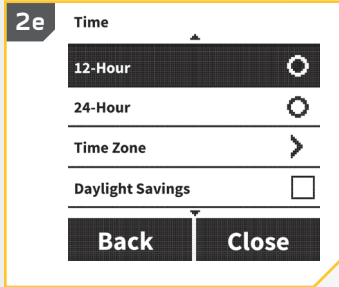

- e. Use the Menu Up  and Menu Down  buttons to find the Daylight Savings menu.
- f. Use the Ok  button to toggle the check box On and Off.

NOTICE: The displayed time will be adjusted for Daylight Savings time when the box is marked in. When the box is unmarked, the displayed time will be unaffected.



Change the GO TO List Sort Order



1

- a. Press the Home  button.
- b. Use the Menu Up  and Menu Down  buttons to find the Options menu at the bottom of the display screen.
- c. Use the Left Softkey  to select the Options menu.
- d. Use the Menu Up  and Menu Down  buttons to find the Sort Order menu. Use the Ok  button to select it.

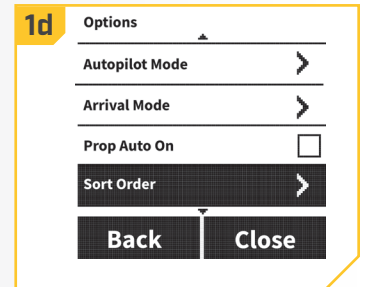
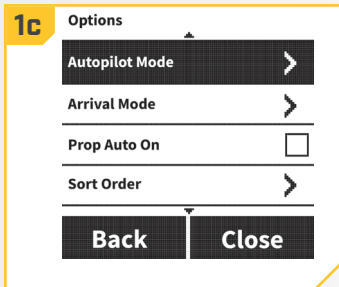
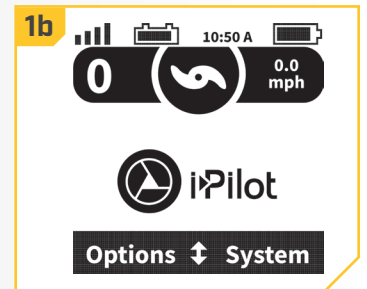
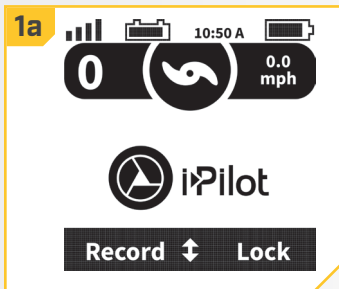
NOTICE: Changing the list sort order organizes how the list of Spot-Locks and iTracks are displayed.



2

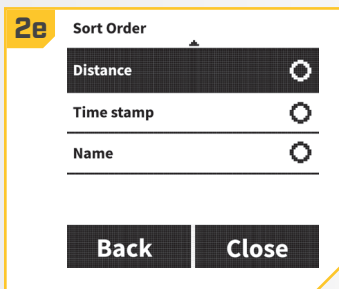

- e. Use the Menu Up  and Menu Down  buttons to find desired Sort Order. Use the Ok  button to select it. The circle to the right of the selected Sort Order will become solid when selected.

NOTICE: Distance will sort a list from the closest to the farthest away. Time stamp will sort a list from the most recent date created to the oldest date. Name will sort in alphabetical order.







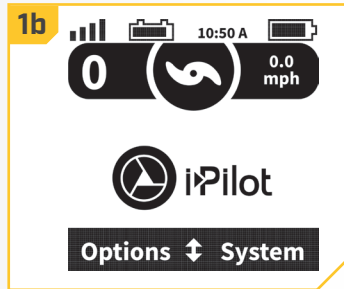
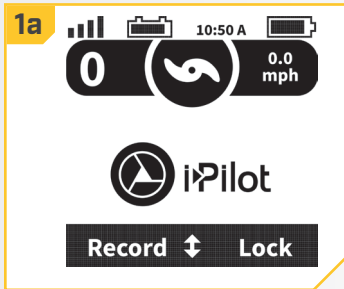

› Set the Remote Auto Off

1

- a. Press the Home  button.
- b. Use the Menu Up  and Menu Down  buttons to find the Options menu at the bottom of the display screen.



2

- c. Use the Left Softkey  to select the Options menu.
- d. Use the Menu Up  and Menu Down  buttons to find the Auto Off menu. Use the Ok  button to select it.
- e. Use the Menu Up  and Menu Down  buttons to find the desired option. Use the Ok  button to select it. The circle to the right of the selected Auto Off option will become solid when selected.

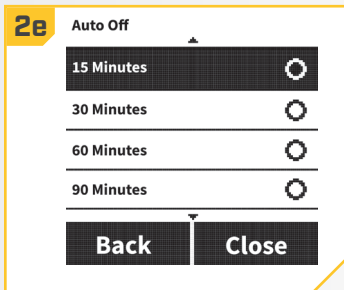
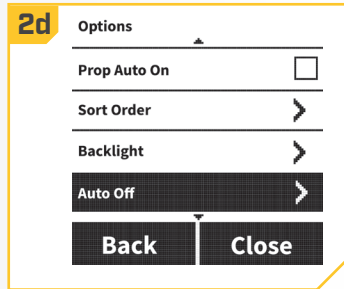
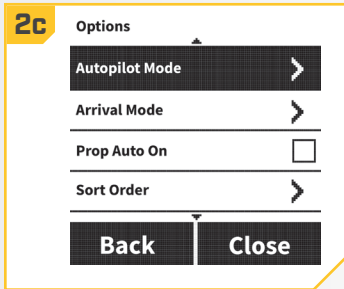



⚠ WARNING

When the motor is being controlled by the i-Pilot system, the controller will continue to perform the last task it was assigned, even when the remote is not powered "on". Be sure to know how to power the motor "on" and "off", and always be alert for unexpected motor movement, such as a turning propeller, even when the remote is powered "off". Refer to the motor Owner's Manual for how to control the motor without the i-Pilot remote and become familiar with it's features including how to turn it "on" and "off". When the remote turns "off" based on the setting chosen with the Auto Off feature, be sure to learn to turn the remote on by pressing the Ok  button and following the on screen prompts. After the remote is powered "on" it will need to connect to the controller.



NOTICE: See the System Startup section of this manual for more information on how to power the Remote "on". The Auto Off will turn the remote off after the selected time frame. Time frame options include 15 Minutes, 30 minutes, 60 Minutes, 90 Minutes, 120 Minutes and Always On.

› To Lock and Unlock the Remote

1

- a. Press the Home  button.
- b. Use the Menu Up  and Menu Down  buttons to find the Lock menu at the bottom of the display screen.

NOTICE: For all motors except the Ulterra and Riptide Ulterra, the Lock menu is a pre-determined selection at the bottom of the display screen when the Home  button is pressed.

- c. Use the Right Softkey  to select the Lock option. Do this by pressing and holding the corresponding softkey for 3 seconds. Once the screen is locked, the menu at the bottom of the display screen will read Unlock.
- d. To Unlock the display screen use either the Left Softkey  or Right Softkey  to select the Unlock option. Do this by pressing and holding the corresponding softkey for 3 seconds.
- e. Once the screen is unlocked, it will return to the Home menu.

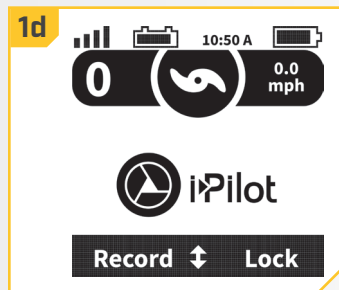
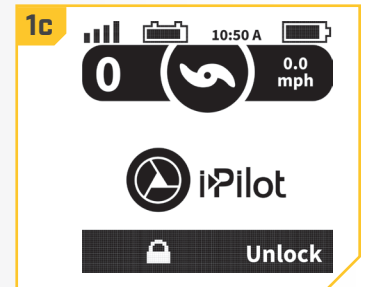
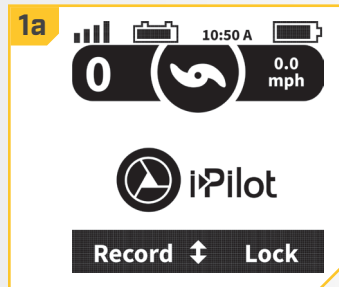

i-PILOT APP

Minn Kota offers an i-Pilot App that can be used to control and update i-Pilot on your motor using a Bluetooth enabled device. The i-Pilot App is available for download on iOS devices through the Apple App store or Android devices through the Google Play store.

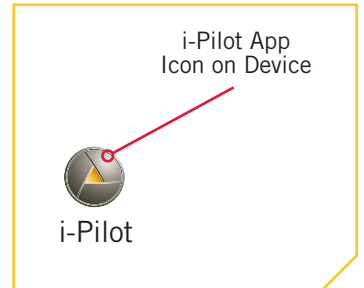

i-Pilot App Home Screen

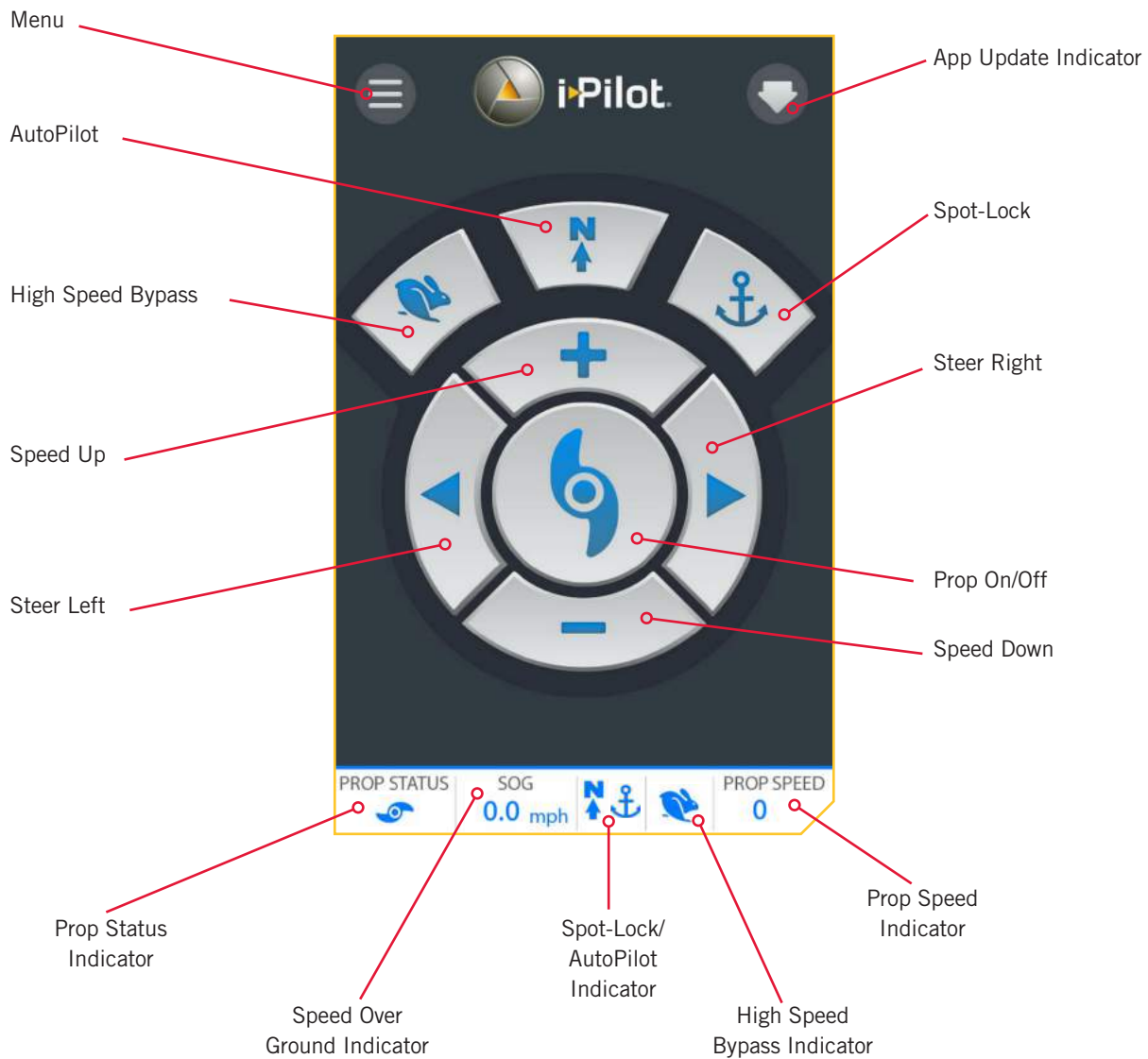

NOTICE: Specifications subject to change without notice. This diagram is for reference only and may differ from your actual app interface. i-Pilot app will only work with i-Pilot enabled motors. Be sure that you download the correct app as other Minn Kota apps will not work with your motor.



APP BUTTONS >



Speed Up & Speed Down

Press to increase or decrease motor speed. Buttons change appearance when Spot-Lock is engaged and Spot-Lock Jog is available.



Spot-Lock Jog

The Speed Up and Speed Down buttons change function when Spot Lock is engaged and Spot-Lock Jog is available. A Heading Sensor is required for Spot-Lock Jog. When Spot-Lock Jog is available, these buttons function to jog the boat either forward or backward.



Steer Left & Steer Right

Press to steer the motor to the left or to the right. While Spot-Lock is enabled, and Spot-Lock Jog is available, these buttons will function to jog the boat to either the left or right if your motor is connected to a Heading Sensor.



Prop On/Off

Pressing this button will turn the Prop on and off.



High Speed Bypass

Bypasses the current motor speed to speed 10. Double press to engage. Single press to disengage.



Spot-Lock

Press to enable Spot-Lock.



AutoPilot

Press to enable AutoPilot or Advanced AutoPilot. The default AutoPilot Mode is set on the remote.

HEADER >



Menu

When selected, the Menu icon gives options to update software for the Control Head and Remote when available, get help, check which version of software is loaded into the i-Pilot remote or Control Head, and register your product.

NOTICE: When the device is not connected to a motor, the Menu will bring up the option to enter Demo Mode. Once the device is connected to a motor, Demo Mode is exited and the option is not available.



App Update Indicator

The App Update Indicator is only available when an update to the app is available. This icon will not appear when the app is up-to-date. This icon is for updates to the app only. For updates to the controller, refer to the "i-Pilot Software Update" option in Menu of the app.

FOOTER >

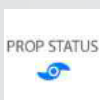
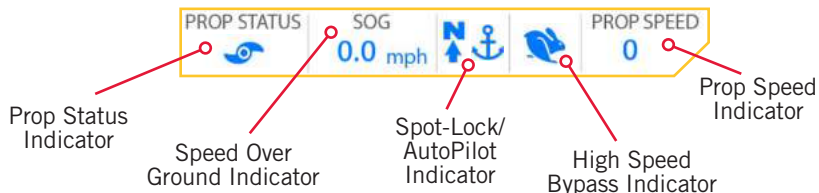

Prop Status Indicator

The Prop Status Indicator contains a Prop icon when the Prop On/Off is turned "on" and is empty when the Prop On/Off is turned "off". The Prop icon will rotate when the Prop is turned on and the speed is above 0 (zero).

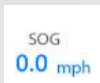

Speed Over Ground Indicator

The Speed Over Ground indicator contains the speed that the boat is moving over the ground in mile per hour increments.



Spot-Lock Indicator

The Spot-Lock Indicator contains the Spot-Lock icon when Spot-Lock is engaged. The icon will look the same regardless of the availability of Spot-Lock Jog.

NOTICE: The Spot-Lock and AutoPilot Indicators are in the same place in the app footer. Since AutoPilot and Spot-Lock cannot be turned on at the same time, this location will contain one icon or the other. When neither feature is turned on, the location will be empty.



AutoPilot Indicator

The AutoPilot Indicator contains the AutoPilot icon when AutoPilot is engaged. The icon will look the same regardless of the AutoPilot Mode that is determined on the remote.

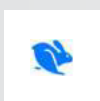

High Speed Bypass Indicator

The High Speed Bypass icon will appear when High Speed Bypass is engaged. The High Speed bypass button requires a double press to engage the feature and make the icon appear. No icon is present when High Speed Bypass is disengaged.

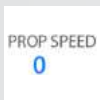

Prop Speed Indicator

The Prop Speed Indicator displays the current Prop speed.

WARNING

The person operating the i-Pilot app is under the same responsibility of operation as if they were operating the i-Pilot either through the remote or any other manner. All safety considerations and precautions for motor operation must be heeded and abide by. This applies to the general "Safety Considerations" at the beginning of this manual and cautions and warnings that are specific to general operation and using features of the i-Pilot system.

LAUNCHING THE APP & DEMO MODE

Launching the app when it is not paired with the motor will allow you to try it out. Every time the app is launched, you must agree with the disclaimer in order to continue. Become familiar with the app screens in order to understand how to operate your motor with the app.



The "Disclaimer" screen when the app is launched.



The "Motor Not Found" screen will appear when the app launches and the motor is either not powered up, connected with Bluetooth or paired to the device.



The buttons are deactivated when the app is not connected to a motor.

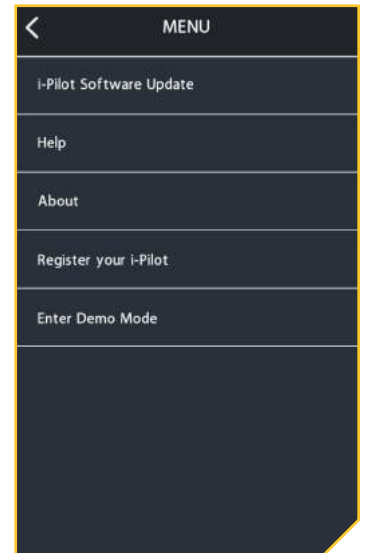

By selecting the Menu, you can "Enter Demo Mode" to engage in the app.



The Home Screen when in Demo Mode.

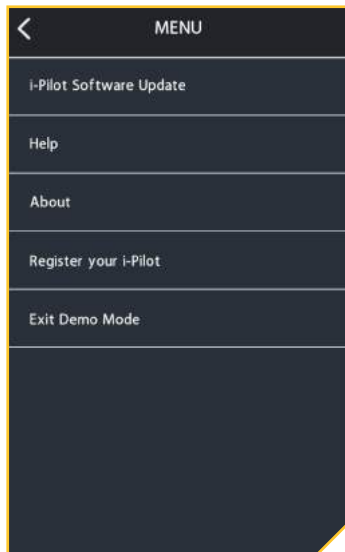

By selecting the Menu while in Demo Mode, you can "Exit Demo Mode".

NOTICE: Once the app is paired with a motor, the full features of the app will be available. Demo Mode is only available when the device is not paired or communicating with a motor.

GETTING STARTED >

> Pairing a Device with the i-Pilot Controller

In order to pair the device with the controller, the app should first be successfully downloaded. You can check that the app was successfully downloaded by opening it on your device. Once you have successfully installed the app and verified installation, close the app to begin the pairing process.

NOTICE: Your device will only be able to connect to a motor and be paired if Bluetooth is enabled on the device you want to pair.

1

- On the device you intend to pair with the i-Pilot controller, turn Bluetooth "on".
- Locate the Pair button on the top of your Control Head. The Control Head contains the i-Pilot controller. Press and hold the Pair button. The Control Head will emit a continuous tone.
- While the Pair button is being held down, scan for the motor on your device. On the device, select the motor from the list of detected devices. Once the device is paired with the motor, the Control Head will emit 3 longer beeps. Once you hear the beeps, the motor was successfully paired and you can stop pressing the Pair button.

NOTICE: In order for the device and your motor to stay connected, Bluetooth needs to remain "on". Once the device is paired with the motor, they will connect and begin communicating with each other.

- Once the device is paired with the motor, and they are connected, the buttons on the Home screen will be blue. If they are not communicating, the buttons will stay deactivated.

NOTICE: You can have up to two devices paired to an i-Pilot controller.

1b Control Head - Ultrera & Riptide Ultrera

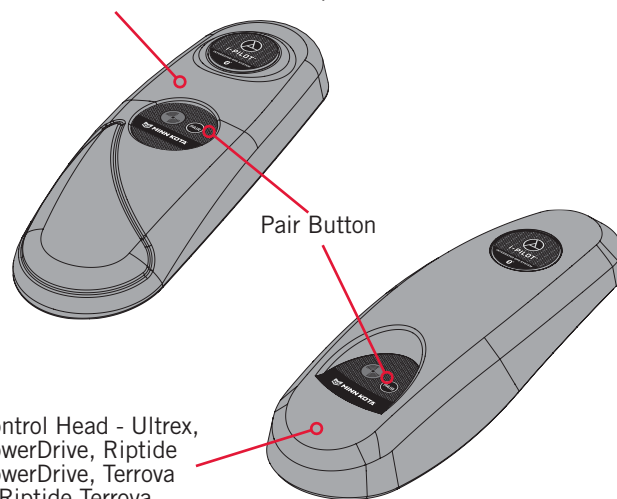

Update the i-Pilot App

NOTICE: It is important to keep the i-Pilot App up-to-date, because all updates to the i-Pilot remote and controller are communicated through the app.

1

- a. Open the i-Pilot app on the device. Check to see if the App Update Indicator icon in the upper right hand corner is present. If no icon is present, the device app is up-to-date.
- b. If the App Update Indicator icon is present, you need to update the app on the device.



› Check Remote and Controller Software Version

The i-Pilot App on the device communicates with the i-Pilot controller, which is in the Control Head of the paired motor. When the App is communicating with a controller, the About screen will display the current version of the app and information about the versions of software in the controller.

1

- a. From the i-Pilot app Home screen, press the Menu icon.
- b. In the Menu screen, select the About option.
- c. The About screen will appear showing the version of the i-Pilot app on the device, the version of i-Pilot software in the controller and the version of the i-Pilot remote software stored in the controller.

NOTICE: Noting the version of the App, controller and remote will help to identify if they are up-to-date and if updates were successful.

NOTICE: The app cannot communicate directly with the i-Pilot remote. The i-Pilot controller holds i-Pilot remote updates that must be updated from the remote. Complete any remote updates after all other updates have been complete. To update the remote, please see the "Update i-Pilot Remote Software" section if this manual.

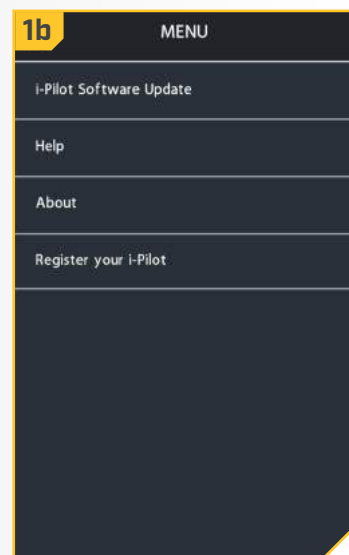

Update the i-Pilot Controller

In order to update the i-Pilot controller, the i-Pilot app on the device should first be updated. To update the app, please refer to the "Update the i-Pilot App" section of this manual. To update the controller, please also confirm that the device is turned on and the controller is paired with the device. To complete this process, please refer to the "Pairing a Device with the i-Pilot Controller" section of this manual. Once both of those are confirmed, please use the following steps to update the controller.

NOTICE: The i-Pilot remote must be updated from the controller, using the remote. Complete any remote updates after all other updates have been complete. To update the remote, please see the "Update i-Pilot Remote Software" section of this manual.

1

- a. Make sure that the following criteria are met:
 - The app is up-to-date.
 - The device has Bluetooth enabled.
 - The device is paired with the controller.
 - The device is within range of the controller during the update process.
- b. Open the i-Pilot app on the device.
- c. Accept the disclaimer to bring up the Home screen. In the upper left hand corner of the Home screen, press the Menu icon to bring up the Menu.
- d. When the Menu screen displays, select the i-Pilot Software Update option.
- e. If the software is up-to-date, the screen will read "Software Up To Date". If the software needs to be updated, there will be information on the screen stating "New Software Available!"
- f. Select "New Software Available!" and information about the current and new versions will display along with a button that reads, "Press to begin Update."
- g. Follow the on-screen prompt to successfully complete the update.

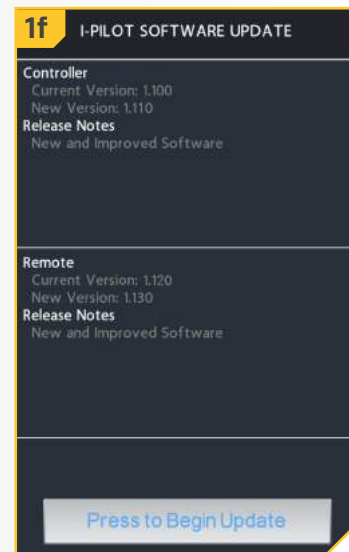
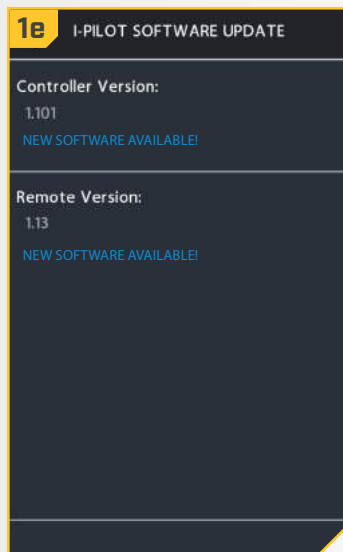
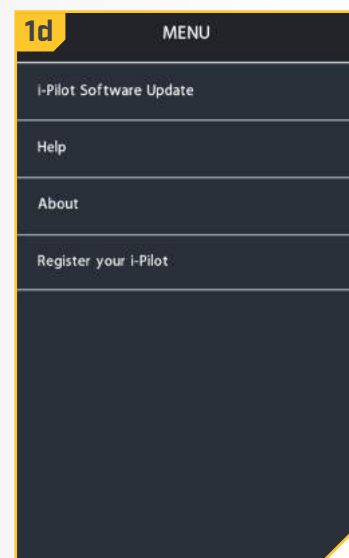

SERVICE & MAINTENANCE

BATTERY REPLACEMENT

TOOLS AND RESOURCES REQUIRED >

- #1 Phillips Screwdriver

INSTALLATION >

- Disconnect the Motor from the battery or make sure that the Remote is out of range from the receiver before replacing the remote batteries.
 - Power the Remote off.
 - Make sure hands are clean, dry and static free. Discharge any static electricity by touching a metal object that is grounded.
 - Using a #1 Phillips Screwdriver, remove the two screws holding the Battery Cover in place.

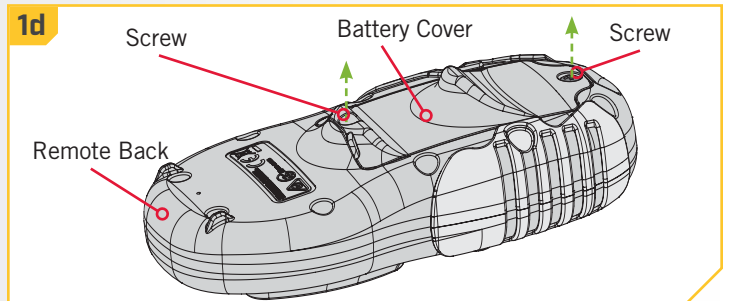
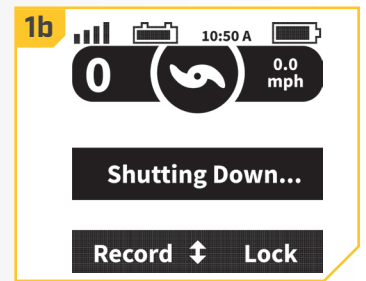
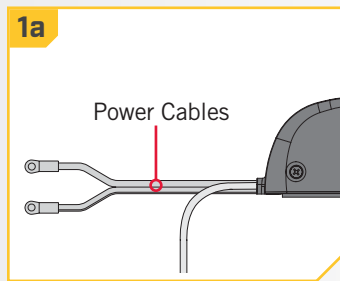

CAUTION

Disconnect the Motor from the battery, or move the Remote out of range from the receiver before replacing the Remote batteries. Discharge static electricity as is can cause damage to the circuit board.

- Lift the Battery Cover from the Remote to gain access to the batteries.
 - Replace the three Alkaline AAA batteries.

CAUTION

It is recommended to use Alkaline AAA batteries.

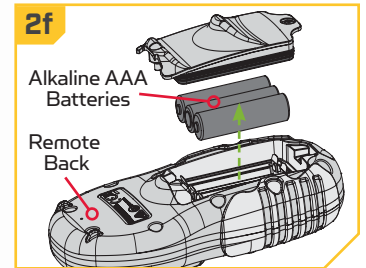
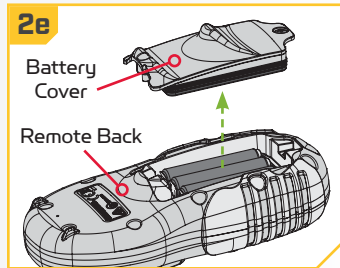

- Make sure the rubber seal on the Battery Cover is seated and replace the cover on the back of the remote.
 - Replace the two screws and tighten them with a #1 Phillips Screwdriver.

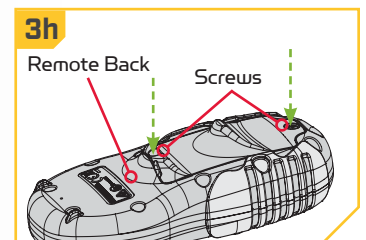
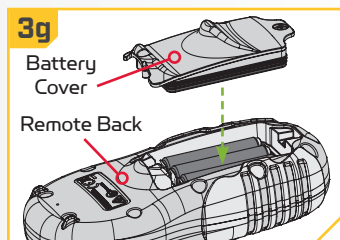









NOTICE: Replace the batteries once a year.

i-PILOT SOFTWARE

CHECKING & UPDATING SOFTWARE

Check Remote and Controller Software Version

1

- Press the Home  button.
- Use the Menu Up  and Menu Down  buttons to find the System menu at the bottom of the display screen.
- Use the Right Softkey  to select the System menu.
- Use the Menu Up  and Menu Down  buttons to find the About option. Use the Ok  button to select it.
- The display screen will show the software version for the i-Pilot remote and controller.
- Press the Right Softkey  or the Home  button to exit the menu.

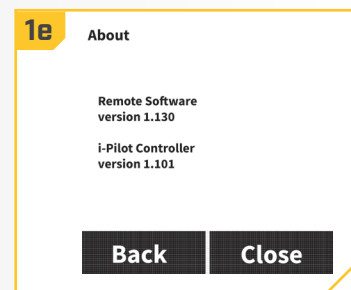
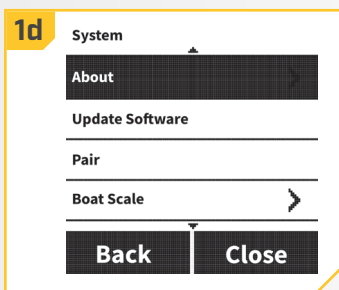
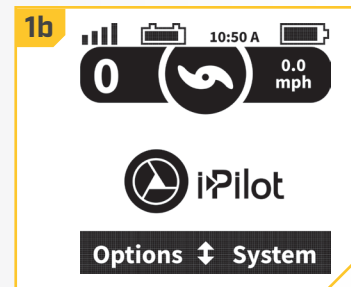
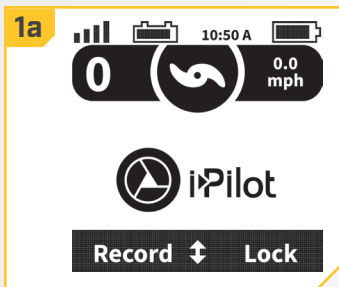





Update i-Pilot Remote Software

1



- Be sure that the software in the Controller is updated before updating the remote. Please see the "i-Pilot App" section of this manual on how to update the Controller.

NOTICE: The software update for the remote will come from the Controller. Make sure the remote stays within range of the Control Head, which contains the Controller during the update process.

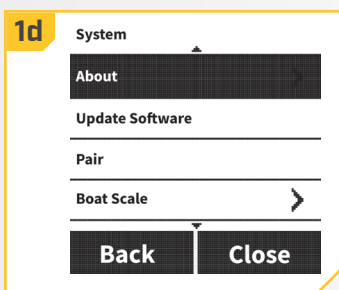
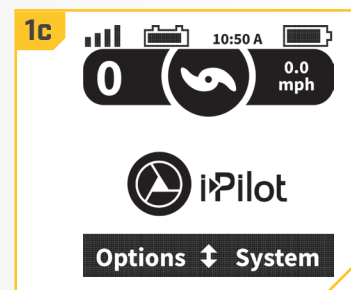
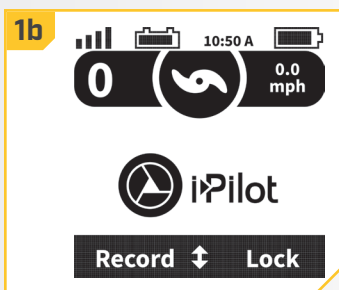
- Once the Controller is up-to-date, press the Home  button.
- Use the Menu Up  and Menu Down  buttons to find the System menu at the bottom of the display screen.
- Use the Right Softkey  to select the System menu.



2

- c. Use the Menu Up  and Menu Down  buttons to find the Update Software option. Use the Ok  button to select it.
- d. If the software is up-to-date, the display screen will read "No New Software Found."
- e. If the software is not up-to-date, the display screen will read "New Software Available" and will list the current version installed and the new version that can be installed.

NOTICE: After selecting the Update Software option on the display screen, take note of the software version that the remote will be updated to. Noting the software version will be helpful to confirm that the software successfully updated after the remote cycles through the update.

- h. Use the Left Softkey  to select Update.
- i. Once the software has been downloaded, the display screen will reboot and the remote will power up and return to the home screen. To confirm that the software successfully updated, follow the steps in the "To Check Remote and Controller Software Version" section of this manual.

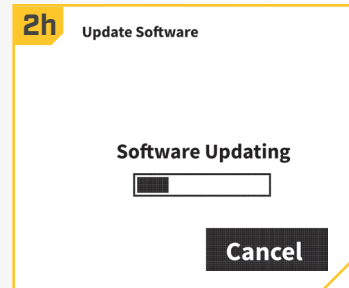
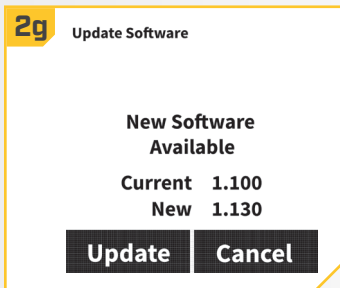
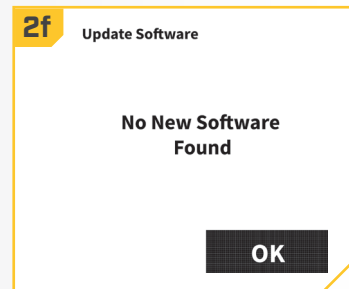
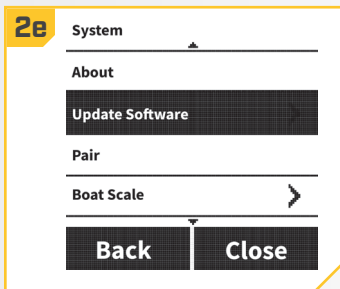



PAIRING A REMOTE WITH A CONTROLLER

PAIRING A REMOTE >

An i-Pilot controller may pair up to 3 remotes. These three remotes can be a combination of standard i-Pilot remotes and Micro remotes. Any additional remotes can be paired using the following steps. Once the maximum number of remotes have been paired, the controller will start replacing a new remote with the oldest paired remote in memory.



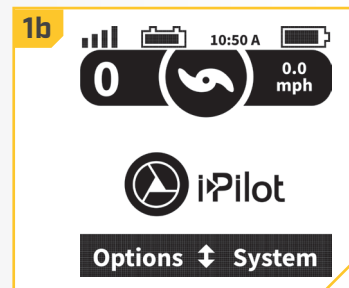
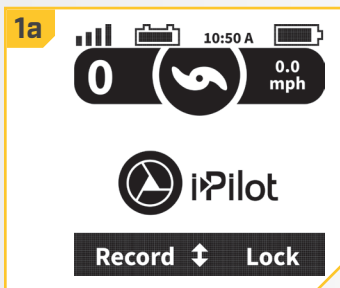

1

- a. Press the Home  button.
- b. Use the Menu Up  and Menu Down  buttons to find the System menu at the bottom of the display screen.

NOTICE: Make sure the remote stays within range of the Control Head during the pairing process.



2

- c. Use the Right Softkey  to select the System menu.
- d. Use the Menu Up  and Menu Down  buttons to find the Pair option.
- e. Before selecting the Pair Option, locate the Pair Button on the top of the Control Head. Press and hold the Pair button. A consistent tone will be emitted from the Control Head.
- f. On the remote, use the Ok  button to select the Pair option from the System menu. The Remote will scan for the motor. Once successfully paired, 3 longer beeps will be emitted from the Control Head and the remote will be paired.

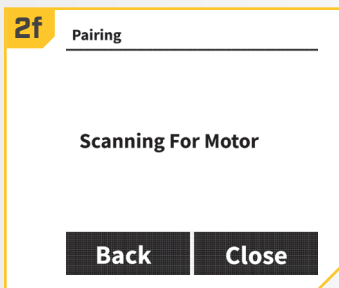
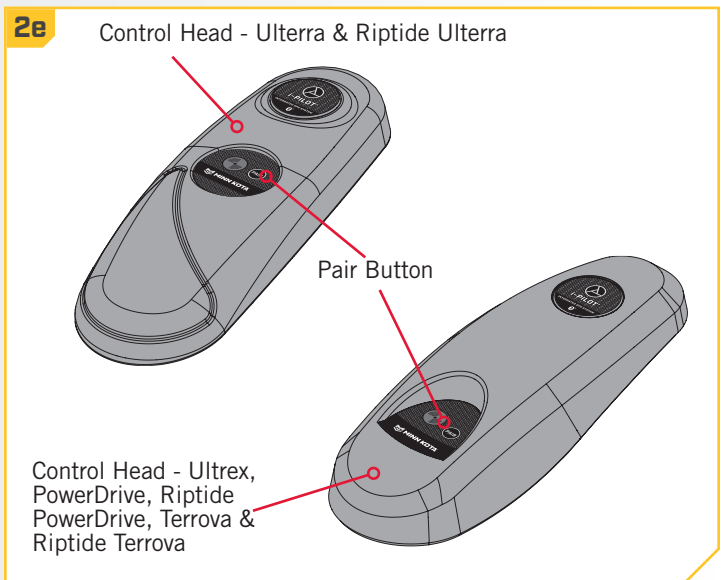
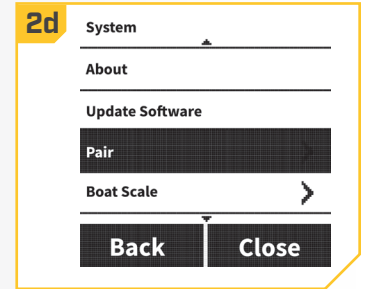
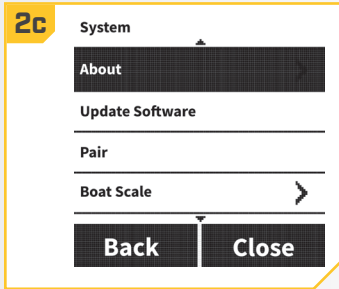



TALON CONTROL

PAIRING, CHECKING & UPDATING SOFTWARE >

> Pair i-Pilot to a Single Talon

The i-Pilot system is paired to the Talon using the Control Head and the Pair Buttons on the Talon Indicator Panel.

- 1**
 - a. Retract the anchor on the Talon by pressing the Up  button.
 - b. Once the Talon is fully retracted, press and hold the Up  button and the Down  button simultaneously on the Indicator Panel. The Depth Indication LEDs will begin to flash blue. Once the LEDs are flashing, release the buttons on the Indicator Panel.
 - c. The Talon will go into Pairing Mode for 20 seconds.
 - d. Locate the Pair Button on the top of the Control Head. Press and hold the Pair button. A consistent tone will be emitted from the Control Head.
 - e. The Control Head will scan for the Talon. Once successfully paired, 3 longer beeps will be emitted from the Control Head and the Talon will be paired.
 - f. If 20 seconds pass while in Pairing Mode and they do not successfully pair, a chirp from the Talon will sound signaling that the Pairing has timed out.
 - g. If the Pair is unsuccessful, repeat the process.

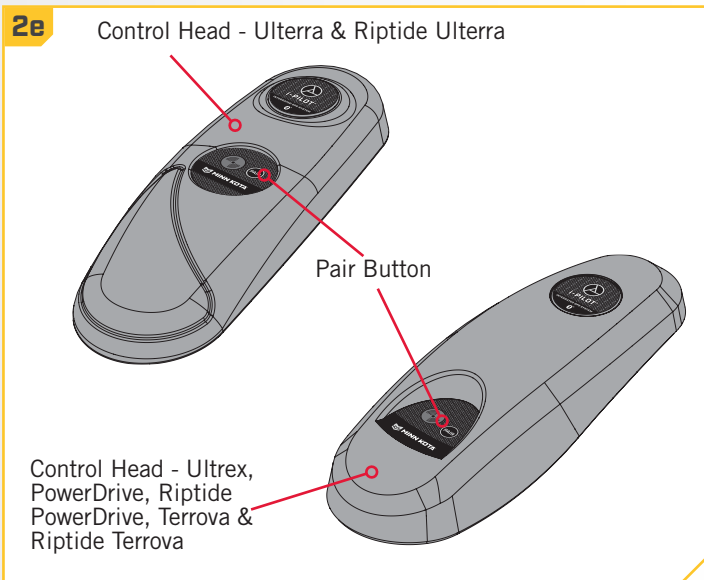









> Pairing i-Pilot with Two Talons

In order for the i-Pilot system to be paired to two Talons, the Talons first need to be paired together. To learn how to pair two Talons together, read the "Pairing Two Talons and Programming the Mounting Location" section of the Talon Manual. Once the Talons are paired together, follow the directions for "Pairing i-Pilot to a Single Talon". Only one Talon needs to be paired with the i-Pilot system.

Check Talon Software Version





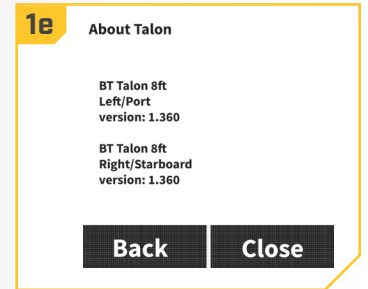
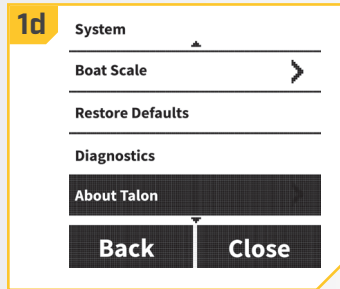
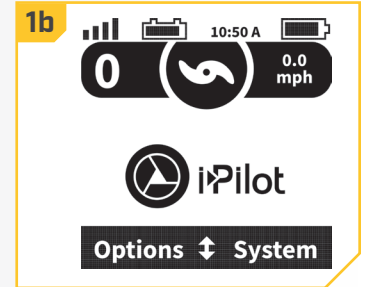
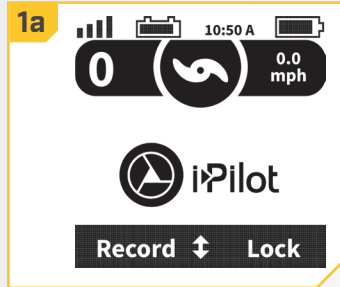

1

- Press the Home  button.
- Use the Menu Up  and Menu Down  buttons to find the System menu at the bottom of the display screen.
- Use the Right Softkey  to select the System menu.
- Use the Menu Up  and Menu Down  buttons to find the About Talon option. Use the Ok  button to select it.
- The display screen will show information about the paired Talon, including Talon length, Port or Starboard location and Talon Software Version.
- Press the Right Softkey  or the Home  button to exit the menu.



Forget the Talon(s) on the i-Pilot System

1

- Press the Home  button.
- Use the Menu Up  and Menu Down  buttons to find the System menu at the bottom of the display screen.
- Use the Right Softkey  to select the System menu.
- Use the Menu Up  and Menu Down  buttons to find the Forget Talon option. Use the Ok  button to select it. A warning message will appear about the Pair being forgotten.

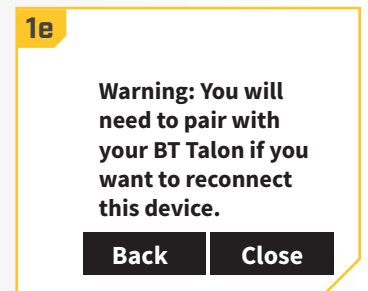
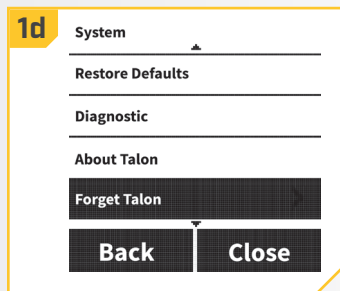
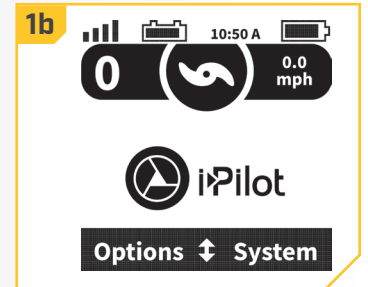
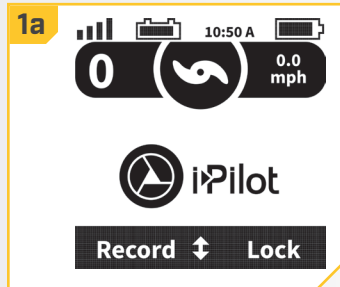

WARNING

You will need to pair with your BT Talon if you want to reconnect this device.

- Select the Left Softkey  to Forget the Talon(s).

GENERAL MAINTENANCE

- Connect the motor to a power source to power up the control head before use.
- Check the remote batteries each time the remote is powered up.
- Inspect the Remote and Control Head before each use to make sure that they are not obstructed. Having a clear view from the Control Head to the sky and an unobstructed sight line between the Remote and Control Head will allow for proper communication.
- Keep the Control Head and Remote away from metal objects including aluminum. Metal objects will cause interference.
- Power down the Remote and disconnect the motor from a power source after each use.
- Verify that the Prop on the Trolling motor is unobstructed when running/ Obstructions can lead to interference and vibration of the compass in the Control Head.

TROUBLESHOOTING

1. The motor is making erratic steering corrections while in AutoPilot, Spot-Lock or Track to Start/End.
 - Be sure to keep all ferrous metallic objects away from the i-Pilot controller as they will have an impact on the built-in compass. Such objects include: anchors, metal framework, etc.
2. When a button on the remote is pressed the motor doesn't always respond.
 - Check if the low battery indicator is on. If so, replace the remote's battery. Check for large obstructions between the remote and the motor.
3. I press a button on the remote and nothing happens.
 - Make sure that the remote is powered on. Only pressing the OK button will power the remote "on".
 - Could be a dead battery in the remote. If the battery was just replaced, open the remote case and verify that all the internal components were properly reinstalled.
 - If the display shows the keypad is locked, unlock the keypad.
4. i-Pilot won't let me turn on certain features like: Advanced AutoPilot, Record, GO TO, Cruise Control or Spot-Lock.
 - Verify that the GPS Signal Strength icon on the LCD shows at least one bar. If there are no bars, i-Pilot will not allow these GPS-based features to be enabled.
5. The remote LCD backlighting will not come on.
 - Check if the low battery indicator icon is on. Backlighting is disabled when a low battery level is detected. Replace the battery.
 - Make sure the backlight is adjusted to the desired brightness. See the "To Adjust the Backlight Brightness" section of this manual for details.

NOTICE: For all other malfunctions, visit an Authorized Service Center. You can search for an Authorized Service Center in your area by visiting our Authorized Service page, found on-line at minnkotamotors.com, or by calling our customer service number at 800-227-6433.



FOR FURTHER TROUBLESHOOTING AND REPAIR

We offer several options to help you troubleshoot and/or repair your product. Please read through the options listed below.



Buy Parts Online

You can buy parts on-line directly from our website at minnkotamotors.com. Orders confirmed by 12 Noon Central Time, with Overnight Shipping selected, should ship the same business day if the parts are in stock. All other orders should ship within the next 3 business days, depending on the shipment method chosen, and if the parts are in stock.



Frequently Asked Questions

We have FAQs available on our website to help answer all of your Minn Kota questions. Visit minnkotamotors.com and click on “Frequently Asked Questions” to find an answer to your question.



Call Us (for U.S. and Canada)

Our consumer service representatives are available Monday – Friday between 7:00 a.m. – 4:30 p.m. CST at 800-227-6433. If you are calling to order parts, please have the 11-character serial number from your product, specific part numbers, and credit card information available. This will help expedite your call and allow us to provide you with the best consumer service possible. You can reference the parts list located in your manual to identify the specific part numbers.



Email Us

You can email our consumer service department with questions regarding your Minn Kota products. To email your question, visit minnkotamotors.com and click on “Support”.



Authorized Service Centers

Minn Kota has over 800 authorized service providers in the United States and Canada where you can purchase parts or get your products repaired. Please visit our Authorized Service Center page on our website to locate a service provider in your area.



Scan to visit Minn Kota service online.



COMPLIANCE STATEMENTS

ENVIRONMENTAL COMPLIANCE STATEMENT

It is the intention of JOME to be a responsible corporate citizen, operating in compliance with known and applicable environmental regulations, and a good neighbor in the communities where we make or sell our products.

WEEE DIRECTIVE

EU Directive 2002/96/EC “Waste of Electrical and Electronic Equipment Directive (WEEE)” impacts most distributors, sellers, and manufacturers of consumer electronics in the European Union. The WEEE Directive requires the producer of consumer electronics to take responsibility for the management of waste from their products to achieve environmentally responsible disposal during the product life cycle.

WEEE compliance may not be required in your location for electrical & electronic equipment (EEE), nor may it be required for EEE designed and intended as fixed or temporary installation in transportation vehicles such as automobiles, aircraft, and boats. In some European Union member states, these vehicles are considered outside of the scope of the Directive, and EEE for those applications can be considered excluded from the WEEE Directive requirement.

This symbol (WEEE wheelie bin) on product indicates the product must not be disposed of with other household refuse. It must be disposed of and collected for recycling and recovery of waste EEE. Johnson Outdoors Inc. will mark all EEE products in accordance with the WEEE Directive. It is our goal to comply in the collection, treatment, recovery, and environmentally sound disposal of those products; however, these requirements do vary within European Union member states. For more information about where you should dispose of your waste equipment for recycling and recovery and/or your European Union member state requirements, please contact your dealer or distributor from which your product was purchased.

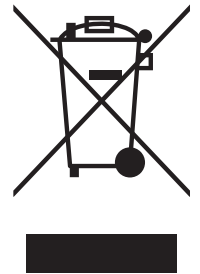

DISPOSAL

Minn Kota motors are not subject to the disposal regulations EAG-VO (electric devices directive) that implements the WEEE directive. Nevertheless never dispose of your Minn Kota motor in a garbage bin but at the proper place of collection of your local town council.

Never dispose of battery in a garbage bin. Comply with the disposal directions of the manufacturer or his representative and dispose of them at the proper place of collection of your local town council.

REGULATORY COMPLIANCE INFORMATION

› i-Pilot System: 2994060, 2994051, 2994061, 2994052, 2994162, 2994159

CONTROLLER

- Contains IC: 216Q-1316
- Contains FCC ID: T7V1316



REMOTE

- Contains IC: 5123A-BGTBLE121LR
- Contains FCC ID: QQQBLE121LR



FCC COMPLIANCE



FCC COMPLIANCE

This device complies with Part 15 of the FCC rules. **Operation is subject to the following two conditions:**

1. This device may not cause harmful interference.
2. This device must accept any interference that may be received, including interference that may cause undesired operation.

Changes or modifications not expressly approved by Johnson Outdoors Marine Electronics, Inc. could void the user's authority to operate this equipment.

NOTICE: This equipment has been tested and found to comply with the limits for a Class B digital device, pursuant to part 15 of the FCC Rules. These limits are designed to provide reasonable protection against harmful interference in a residential installation. This equipment generates, uses and can radiate radio frequency energy and, if not installed and used in accordance with the instructions, may cause harmful interference to radio communications. However, there is no guarantee that interference will not occur in a particular installation. **If this equipment does cause harmful interference to radio or television reception, which can be determined by turning the equipment off and on, the user is encouraged to try to correct the interference by one or more of the following measures:**

- Reorient or relocate the receiving antenna.
- Increase the separation between the equipment and receiver.
- Connect the equipment into an outlet on a circuit different from that to which the receiver is connected.
- Consult the dealer or an experienced radio/TV technician for help.

INDUSTRY CANADA COMPLIANCE

This product meets the applicable Industry Canada technical specifications. Operation is subject to the following two conditions: (1) this device may not cause interference, and (2) this device must accept any interference, including interference that may cause undesired operation of the device.

Changes or modifications not expressly approved by Johnson Outdoors Marine Electronics, Inc. could void the user's authority to operate this equipment.

RADIO OPERATION

CONTROLLER

- Frequency band: 2402 MHz to 2480 MHz
- Maximum RF power transmitted: +10 dBm

REMOTE

- Frequency band: 2402 MHz to 2480 MHz
- Maximum RF power transmitted: +10 dBm

TRADEMARKS

Minn Kota®, Riptide®, i-Pilot®, AutoPilot™, CoPilot™, Link™, PowerDrive™, Terrova™, Ulterra™ are trademarked by or registered trademarks of Johnson Outdoors Marine Electronics, Inc.

The Bluetooth® word mark and logos are registered trademarks owned by Bluetooth SIG, Inc. and any use of such marks by Johnson Outdoors Inc is under license. Other trademarks and trade names are those of their respective owners.

CE MASTER USER MANUAL [FOR CE CERTIFIED MODELS]



PARTS DIAGRAM & PARTS LIST

i-PILOT

POWERDRIVE, RIPTIDE POWERDRIVE, TERROVA, RIPTIDE TERROVA, ULTERRA, RIPTIDE ULTERRA & ULTREX

The parts diagram and parts list provides Minn Kota® WEEE compliance disassembly instructions. For more information about where you should dispose of your waste equipment for recycling and recovery and/or your European Union member state requirements, please contact your dealer or distributor from which your product was purchased. Tools required, but not limited to: flat head screwdriver, Phillips screwdriver, socket set, pliers, wire cutters.

i-PILOT REMOTE & HEADING SENSOR

Remote & Heading Sensor Parts Diagram

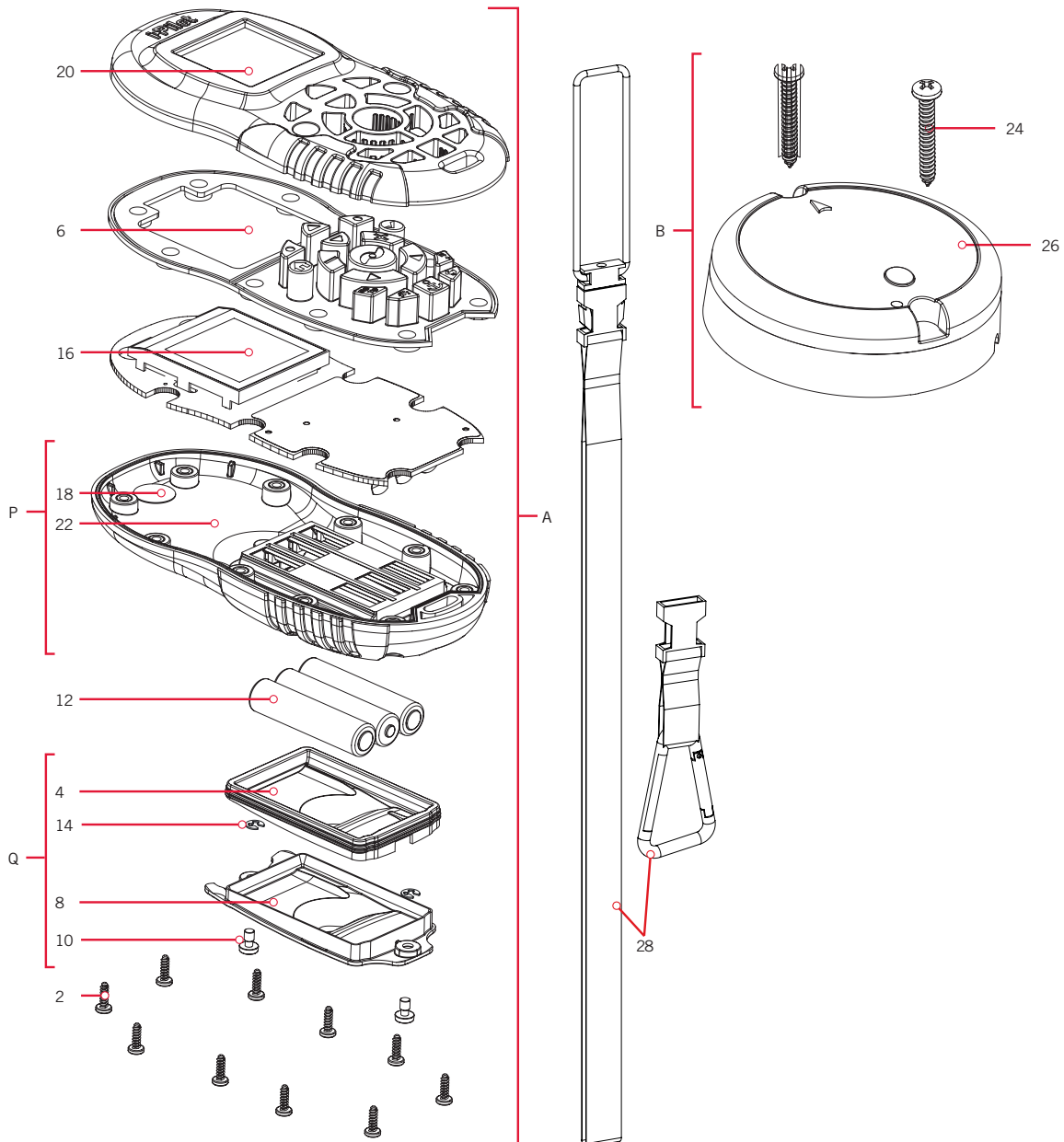

PARTS DIAGRAM & PARTS LIST

Remote & Heading Sensor Parts List

| Assembly | Part # | Description | Quantity |
|----------|---------|--|----------|
| A | 2994075 | REMOTE ASY, iPILOT | 1 |
| B | 2996400 | HEADING SENSOR ASSEMBLY | 1 |
| P | 2882557 | CASE BTM, WINDOW ASM & VENT DCL | 1 |
| Q | 2886423 | BATTERY DOOR, SEAL, SCREW KIT | 1 |
| Item | Part # | Description | Quantity |
| 2 | 2373443 | SCREW-2.5MMx8MM DELTA PT TORX | 10 |
| 4 | 2374647 | SEAL, BATTERY DOOR, iPILOT 1.6 | 1 |
| 6 | 2375134 | KEYPAD, iPILOT 1.6 REMOTE | 1 |
| 8 | 2376423 | DOOR, BATTERY, iPILOT 1.6 | 1 |
| 10 | 2383442 | SCREW-3MM X .5 PPH MACHINE | 2 |
| 12 | ✘ | BATTERY AAA, iPILOT 1.6 | 3 |
| 14 | 2393000 | E-CLIP, 3MM, SS | 2 |
| 16 | ✘ | PCB ASY, iPILOT 1.6 REMOTE | 1 |
| 18 | ✘ | DECAL, VENT PATCH, 1/2" OD | 1 |
| 20 | 2992552 | CASE TOP w/WINDOW ASSY | 1 |
| 22 | ✘ | CASE BTM w/WINDOW ASSY | 1 |
| 24 | 2393400 | SCREW-#8-18X1-1/2 PPH TY AB SS *STAINLESS STEEL* | 2 |
| 26 | ✘ | HEADING SENSOR | 1 |
| 28 | 2390800 | LANYARD, REMOTE W/ CARABEENER | 1 |

✘ This part is included in an assembly and cannot be ordered individually.

i-PILOT CONTROL HEAD

Control Head Parts Diagram

Ultrax, Terrova & Riptide Terrova

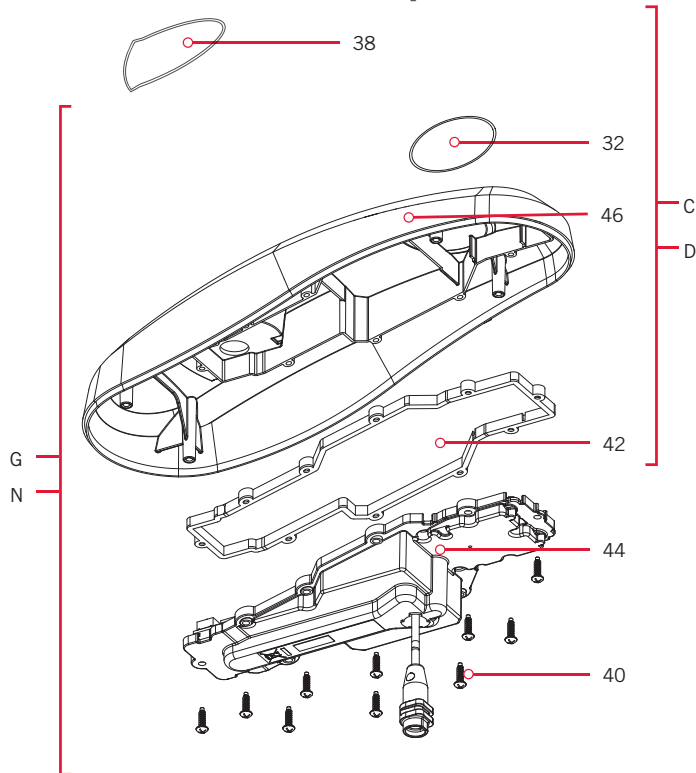

PowerDrive & Riptide PowerDrive

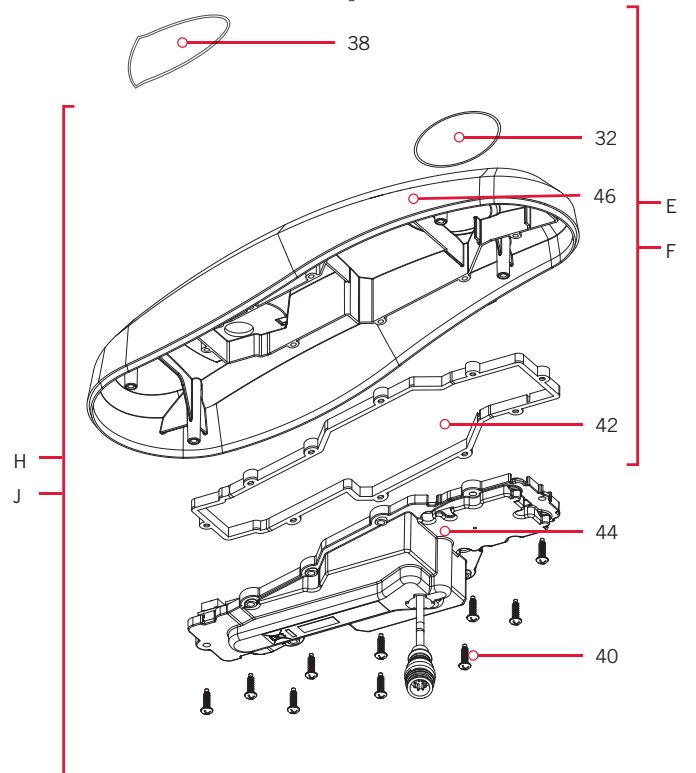

Ulterra & Riptide Ulterra

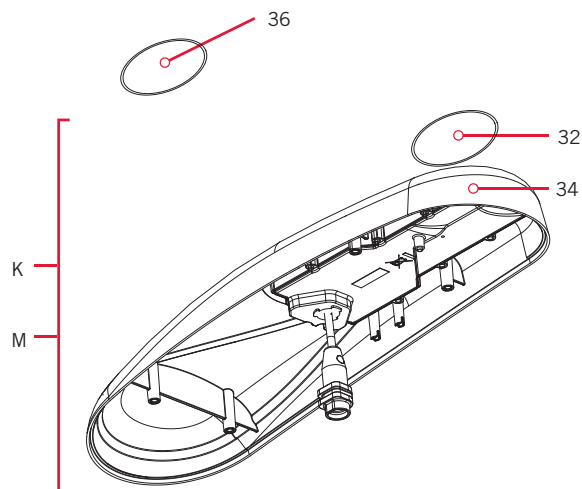

PARTS DIAGRAM & PARTS LIST

Control Head Parts List

| Assembly | Part # | Description | Quantity |
|----------|---------|--|----------|
| C | 2770233 | COVER KIT, IPLT 1.6 TRV,ULTREX *TERROVA* *ULTREX* *FRESHWATER* | 1 |
| D | 2770235 | COVER KIT, IPLT 1.6 RT TERROVA *RIPTIDE TERROVA* *SALTWATER* | 1 |
| E | 2770218 | COVER KIT, IPLT 1.6 POWERDRIVE *POWERDRIVE* *FRESHWATER* | 1 |
| F | 2770219 | COVER KIT,IPLT 1.6 RT PWRDRIVE *RIPTIDE POWERDRIVE* *SALTWATER* | 1 |
| G | 2774178 | MOTOR KIT, IPLT 1.6 RT TERROVA *RIPTIDE TERROVA* *SALTWATER* *CONTROLLER* *NO REMOTE* | 1 |
| H | 2774125 | MOTOR KIT, IPLT 1.6 POWERDRIVE *POWERDRIVE* *FRESHWATER* *CONTROLLER* *NO REMOTE* | 1 |
| J | 2774126 | MOTOR KIT,IP 1.6 RT POWERDRIVE *RIPTIDE POWERDRIVE* *SALTWATER* *CONTROLLER* *NO REMOTE* | 1 |
| K | 2774119 | MOTOR KIT, IPILOT 1.6 ULTERRA *ULTERRA* *FRESHWATER* *CONTROLLER* *NO REMOTE* | 1 |
| M | 2774116 | MOTOR KIT, IPLT 1.6 RT ULTERRA *RIPTIDE ULTERRA* *SALTWATER* *CONTROLLER* *NO REMOTE* | 1 |
| N | 2774176 | MOTOR KIT, IPLT 1.6 TRV,UTREX *ULTREX* *FRESHWATER* *CONTROLLER* *NO REMOTE* | 1 |
| Item | Part # | Description | Quantity |
| 32 | 2395545 | DECAL, DOMED IPILOT FW *FRESHWATER* *ULTERRA* *I-PILOT* *POWERDRIVE* *ULTREX* *TERROVA* | 1 |
| | 2395546 | DECAL, DOMED IPILOT SW *SALTWATER* *RIPTIDE ULTERRA* *I-PILOT* *RIPTIDE TERROVA* *RIPTIDE POWERDRIVE* | 1 |
| 34 | * | CTRL HEAD ASY, IPILOT 1.6 ULT *FRESHWATER* *ULTERRA* | 1 |
| | * | CTRL HEAD ASY, IP 1.6 RT ULT *SALTWATER* *RIPTIDE ULTERRA* | 1 |
| 36 | 2205534 | DECAL-GENERIC, PUSH BTN TOP FW *FRESHWATER* *ULTERRA* *PUSH BUTTON* | 1 |
| | 2205535 | DECAL-GENERIC, PUSH BTN TOP SW *SALTWATER* *RIPTIDE ULTERRA* *PUSH BUTTON* | 1 |
| 38 | 2315730 | DECAL-GENERIC, PUSH BTN TOP FW *TERROVA* *ULTREX* *POWERDRIVE* *FRESHWATER* | 1 |
| | 2315731 | DECAL-GENERIC, PUSH BTN TOP SW *RIPTIDE TERROVA* *RIPTIDE POWERDRIVE* *SALTWATER* | 1 |
| 40 | 2383473 | SCREW-#6 X .5 BRASS HI-LO*FRESHWATER* *SALTWATER* *RIPTIDE TERROVA* *POWERDRIVE* *RIPTIDE POWERDRIVE* *ULTREX* *TERROVA* | 10 |
| 42 | 2376940 | GASKET,COMP-GPS MODULE *FRESHWATER* *SALTWATER* *RIPTIDE TERROVA* *POWERDRIVE* *RIPTIDE POWERDRIVE* *ULTREX* *TERROVA* | 1 |
| 44 | * | CTRL ASY, IPILOT 1.6 TER/UTX *SALTWATER* *RIPTIDE TERROVA* *FRESHWATER* *ULTREX* *TERROVA* | 1 |
| | * | CTRL ASY, IPILOT 1.6 PD *FRESHWATER* *POWERDRIVE* *SALTWATER* *RIPTIDE POWERDRIVE* | 1 |
| 46 | * | COVER,CTRL BOX IP, UTX, T2, V3 *FRESHWATER* *ULTREX* *TERROVA* | 1 |
| | * | COVER,CTRL BOX IP, ST/T2,SP/V3 *RIPTIDE TERROVA* *SALTWATER* | 1 |
| | * | COVER,CTRL BOX IP, V3 PRINTED *FRESHWATER* *POWERDRIVE* | 1 |
| | * | COVER,CTRL BOX IP,RT/V3 PRINTD *RIPTIDE POWERDRIVE* *SALTWATER* | 1 |

* This part is included in an assembly and cannot be ordered individually.

NOTES



A large area of the page containing numerous horizontal lines, designed for taking notes or recording information.

RECOMMENDED ACCESSORIES

ON-BOARD & PORTABLE BATTERY CHARGERS

Stop buying new batteries and start taking care of the ones you've got. Many chargers can actually damage your battery over time – creating shorter run times and shorter overall life. Digitally controlled Minn Kota chargers are designed to provide the fastest charge that protect and extend battery life.



MK212PC



MK210D



MK110PD

TALON SHALLOW WATER ANCHOR

Introducing the all-new, sleek redesigned Talon. Talon is the only shallow water anchor with up to 15' of anchoring depth, multiple anchoring modes, and control from the bow, transom, console, remote or mobile device.



BUILT-IN WORK LIGHT

Lets you tie lines and work from the transom any time of day — or night. Includes both white and blue LED lights with three brightness settings.



UP TO 15' DEEP

Control more water and catch more fish with the first 15' shallow water anchor.



MORE CONTROL OPTIONS

- Control Panel
- Wireless Remote
- Mobile App
- Wireless Foot Switch
- Humminbird® Connectivity
- i-Pilot® & i-Pilot Link™ Remote



BLUETOOTH® CONNECTIVITY

Lets you control Talon from your mobile device and easily update it. Also opens up communication to other control options.

MINN KOTA ACCESSORIES

We offer a wide variety of trolling motor accessories, including:

- 60-Amp Circuit Breaker
- Mounting Brackets
- Stabilizer Kits
- Extension Handles
- Battery Connectors
- Battery Boxes
- Quick Connect Plugs



minnkotamotors.com



Part #2397100

Minn Kota Consumer & Technical Service
Johnson Outdoors Marine Electronics, Inc.
PO Box 8129
Mankato, MN 56001

121 Power Drive
Mankato, MN 56001
Phone (800) 227-6433
Fax (800) 527-4464



©2018 Johnson Outdoors Marine Electronics, Inc.
All rights reserved.

ECN 38528

Rev F

05/18